

# 16-bit Proprietary Microcontroller

CMOS

## F<sup>2</sup>MC-16FX MB96370 Series

### MB96F378\*1/F379\*1

#### ■ DESCRIPTION

MB96370 series is based on Fujitsu's advanced 16FX architecture (16-bit with instruction pipeline for RISC-like performance). The CPU uses the same instruction set as the established 16LX series - thus allowing for easy migration of 16LX Software to the new 16FX products. 16FX improvements compared to the previous generation include significantly improved performance - even at the same operation frequency, reduced power consumption and faster start-up time.

For highest processing speed at optimized power consumption an internal PLL can be selected to supply the CPU with up to 40MHz operation frequency from an external 4MHz resonator. The result is a minimum instruction cycle time of 25ns going together with excellent EMI behavior. An on-chip clock modulation circuit significantly reduces emission peaks in the frequency spectrum. The emitted power is minimized by the on-chip voltage regulator that reduces the internal CPU voltage. A flexible clock tree allows to select suitable operation frequencies for peripheral resources independent of the CPU speed.

\*1: These devices are under development and specification is preliminary. These products under development may change its specification without notice.

Note: F<sup>2</sup>MC is the abbreviation of FUJITSU Flexible Microcontroller.

For the information for microcontroller supports, see the following web site.

This web site includes the "**Customer Design Review Supplement**" which provides the latest cautions on system development and the minimal requirements to be checked to prevent problems before the system development.

<http://edevice.fujitsu.com/micom/en-support/>

# MB96370 Series

## ■ FEATURES

Feature	Description
Technology	<ul style="list-style-type: none"> <li>0.18<math>\mu</math>m CMOS</li> </ul>
CPU	<ul style="list-style-type: none"> <li>F<sup>2</sup>MC-16FX CPU</li> <li>Up to 40 MHz internal, 25 ns instruction cycle time</li> <li>Optimized instruction set for controller applications (bit, byte, word and long-word data types; 23 different addressing modes; barrel shift; variety of pointers)</li> <li>8-byte instruction execution queue</li> <li>Signed multiply (16-bit <math>\times</math> 16-bit) and divide (32-bit/16-bit) instructions available</li> </ul>
System clock	<ul style="list-style-type: none"> <li>On-chip PLL clock multiplier (x1 - x25, x1 when PLL stop)</li> <li>3 MHz - 16 MHz external crystal oscillator clock (maximum frequency when using ceramic resonator depends on Q-factor).</li> <li>Up to 40 MHz external clock</li> <li>32-100 kHz subsystem quartz clock</li> <li>100kHz/2MHz internal RC clock for quick and safe startup, oscillator stop detection, watchdog</li> <li>Clock source selectable from main- and subclock oscillator (part number suffix "W") and on-chip RC oscillator, independently for CPU and 2 clock domains of peripherals.</li> <li>Low Power Consumption - 13 operating modes : (different Run, Sleep, Timer modes, Stop mode)</li> <li>Clock modulator</li> </ul>
On-chip voltage regulator	<ul style="list-style-type: none"> <li>Internal voltage regulator supports reduced internal MCU voltage, offering low EMI and low power consumption figures</li> </ul>
Low voltage reset	<ul style="list-style-type: none"> <li>Reset is generated when supply voltage is below minimum.</li> </ul>
Code Security	<ul style="list-style-type: none"> <li>Protects ROM content from unintended read-out</li> </ul>
Memory Patch Function	<ul style="list-style-type: none"> <li>Replaces ROM content</li> <li>Can also be used to implement embedded debug support</li> </ul>
DMA	<ul style="list-style-type: none"> <li>Automatic transfer function independent of CPU, can be assigned freely to resources</li> </ul>
Interrupts	<ul style="list-style-type: none"> <li>Fast Interrupt processing</li> <li>8 programmable priority levels</li> <li>Non-Maskable Interrupt (NMI)</li> </ul>
Timers	<ul style="list-style-type: none"> <li>Three independent clock timers (23-bit RC clock timer, 23-bit Main clock timer, 17-bit Sub clock timer)</li> <li>Watchdog Timer</li> </ul>

Feature	Description
CAN	<ul style="list-style-type: none"> <li>• Supports CAN protocol version 2.0 part A and B</li> <li>• ISO16845 certified</li> <li>• Bit rates up to 1 Mbit/s</li> <li>• 32 message objects</li> <li>• Each message object has its own identifier mask</li> <li>• Programmable FIFO mode (concatenation of message objects)</li> <li>• Maskable interrupt</li> <li>• Disabled Automatic Retransmission mode for Time Triggered CAN applications</li> <li>• Programmable loop-back mode for self-test operation</li> </ul>
USART	<ul style="list-style-type: none"> <li>• Full duplex USARTs (SCI/LIN)</li> <li>• Wide range of baud rate settings using a dedicated reload timer</li> <li>• Special synchronous options for adapting to different synchronous serial protocols</li> <li>• LIN functionality working either as master or slave LIN device</li> </ul>
I <sup>2</sup> C	<ul style="list-style-type: none"> <li>• Up to 400 kbps</li> <li>• Master and Slave functionality, 8-bit and 10-bit addressing</li> </ul>
A/D converter	<ul style="list-style-type: none"> <li>• SAR-type</li> <li>• 10-bit resolution</li> <li>• Signals interrupt on conversion end, single conversion mode, continuous conversion mode, stop conversion mode, activation by software, external trigger or reload timer</li> </ul>
Reload Timers	<ul style="list-style-type: none"> <li>• 16-bit wide</li> <li>• Prescaler with <math>1/2^1</math>, <math>1/2^2</math>, <math>1/2^3</math>, <math>1/2^4</math>, <math>1/2^5</math>, <math>1/2^6</math> of peripheral clock frequency</li> <li>• Event count function</li> </ul>
Free Running Timers	<ul style="list-style-type: none"> <li>• Signals an interrupt on overflow, supports timer clear upon match with Output Compare (0, 4), Prescaler with 1, <math>1/2^1</math>, <math>1/2^2</math>, <math>1/2^3</math>, <math>1/2^4</math>, <math>1/2^5</math>, <math>1/2^6</math>, <math>1/2^7</math>, <math>1/2^8</math> of peripheral clock frequency</li> </ul>
Input Capture Units	<ul style="list-style-type: none"> <li>• 16-bit wide</li> <li>• Signals an interrupt upon external event</li> <li>• Rising edge, falling edge or rising &amp; falling edge sensitive</li> </ul>
Output Compare Units	<ul style="list-style-type: none"> <li>• 16-bit wide</li> <li>• Signals an interrupt when a match with 16-bit I/O Timer occurs</li> <li>• A pair of compare registers can be used to generate an output signal.</li> </ul>
Programmable Pulse Generator	<ul style="list-style-type: none"> <li>• 16-bit down counter, cycle and duty setting registers</li> <li>• Interrupt at trigger, counter borrow and/or duty match</li> <li>• PWM operation and one-shot operation</li> <li>• Internal prescaler allows 1, 1/4, 1/16, 1/64 of peripheral clock as counter clock and Reload timer overflow as clock input</li> <li>• Can be triggered by software or reload timer</li> </ul>

# MB96370 Series

Feature	Description
Stepper Motor Controller	<ul style="list-style-type: none"> <li>• Stepper Motor Controller with integrated high current output drivers</li> <li>• Four high current outputs for each channel</li> <li>• Two synchronized 8/10-bit PWMs per channel</li> <li>• Internal prescaling for PWM clock: 1, 1/4, 1/5, 1/6, 1/8, 1/10, 1/12, 1/16 of peripheral clock</li> <li>• Separate power supply for high current output drivers</li> </ul>
LCD Controller	<ul style="list-style-type: none"> <li>• LCD controller with up to 4 COM × 72 SEG</li> <li>• Internal or external voltage generation</li> <li>• Duty cycle: Selectable from options: 1/2, 1/3 and 1/4</li> <li>• Fixed 1/3 bias</li> <li>• Programmable frame period</li> <li>• Clock source selectable from three options (peripheral clock, subclock or RC oscillator clock)</li> <li>• On-chip drivers for internal divider resistors or external divider resistors</li> <li>• On-chip data memory for display</li> <li>• LCD display can be operated in Timer Mode</li> <li>• Blank display: selectable</li> <li>• All SEG, COM and V pins can be switched between general and specialized purposes</li> <li>• External divided resistors can be also used to shut off the current when LCD is deactivated</li> </ul>
Sound Generator	<ul style="list-style-type: none"> <li>• 8-bit PWM signal is mixed with tone frequency from 16-bit reload counter</li> <li>• PWM clock by internal prescaler: 1, 1/2, 1/4, 1/8 of peripheral clock</li> </ul>
Real Time Clock	<ul style="list-style-type: none"> <li>• Can be clocked either from sub oscillator (devices with part number suffix "W"), main oscillator or from the RC oscillator</li> <li>• Facility to correct oscillation deviation of Sub clock or RC oscillator clock (clock calibration)</li> <li>• Read/write accessible second/minute/hour registers</li> <li>• Can signal interrupts every half second/second/minute/hour/day</li> <li>• Internal clock divider and prescaler provide exact 1s clock</li> </ul>
External Interrupts	<ul style="list-style-type: none"> <li>• Edge sensitive or level sensitive</li> <li>• Interrupt mask and pending bit per channel</li> <li>• Each available CAN channel RX has an external interrupt for wake-up</li> <li>• Selected USART channels SIN have an external interrupt for wake-up</li> </ul>
Non Maskable Interrupt	<ul style="list-style-type: none"> <li>• Disabled after reset</li> <li>• Once enabled, can not be disabled other than by reset.</li> <li>• Level high or level low sensitive</li> <li>• Pin shared with external interrupt 0.</li> </ul>

Feature	Description
External bus interface	<ul style="list-style-type: none"> <li>• 8-bit or 16-bit bidirectional data</li> <li>• Up to 24-bit addresses</li> <li>• 6 chip select signals</li> <li>• Multiplexed address/data lines</li> <li>• Non-multiplexed address/data lines</li> <li>• Wait state request</li> <li>• External bus master possible</li> <li>• Timing programmable</li> </ul>
Alarm comparator	<ul style="list-style-type: none"> <li>• Monitors an external voltage and generates an interrupt in case of a voltage lower or higher than the defined thresholds</li> <li>• Threshold voltages defined externally or generated internally</li> <li>• Status is readable, interrupts can be masked separately</li> </ul>
I/O Ports	<ul style="list-style-type: none"> <li>• Virtually all external pins can be used as general purpose I/O</li> <li>• All push-pull outputs (except when used as I<sup>2</sup>C SDA/SCL line)</li> <li>• Bit-wise programmable as input/output or peripheral signal</li> <li>• Bit-wise programmable input enable</li> <li>• Bit-wise programmable input levels: Automotive / CMOS-Schmitt trigger / TTL</li> <li>• Bit-wise programmable pull-up resistor</li> <li>• Bit-wise programmable output driving strength for EMI optimization</li> </ul>
Packages	<ul style="list-style-type: none"> <li>• 144-pin plastic LQFP M08/12</li> </ul>
Flash Memory	<ul style="list-style-type: none"> <li>• Supports automatic programming, Embedded Algorithm</li> <li>• Write/Erase/Erase-Suspend/Resume commands</li> <li>• A flag indicating completion of the algorithm</li> <li>• Number of erase cycles: 10,000 times</li> <li>• Data retention time: 20 years</li> <li>• Erase can be performed on each sector individually</li> <li>• Sector protection</li> <li>• Flash Security feature to protect the content of the Flash</li> <li>• Low voltage detection during Flash erase</li> </ul>

# MB96370 Series

## ■ PRODUCT LINEUP

Features		MB96V300	MB96(F)37x
Product type		Evaluation sample	Flash product: MB96F37x Mask ROM product: MB9637x
Product options			
YS	NA	Low voltage reset persistently on / Single clock devices	
RS		Low voltage reset can be disabled / Single clock devices	
YW		Low voltage reset persistently on / Dual clock devices	
RW		Low voltage reset can be disabled / Dual clock devices	
TS		indep. 32KB Flash / Low voltage reset persistently on / Single clock devices	
HS		indep. 32KB Flash / Low voltage reset can be disabled / Single clock devices	
TW		indep. 32KB Flash / Low voltage reset persistently on / Dual clock devices	
HW		indep. 32KB Flash / Low voltage reset can be disabled / Dual clock devices	
Flash/ROM	RAM		
576KB [Flash A: 544KB, Flash B : 32KB]	28KB	ROM/Flash memory emulation by external RAM, 92KB internal RAM	MB96F378T <sup>*1</sup> , MB96F378H <sup>*1</sup>
832KB [Flash A: 544KB Flash B: 288KB]	32KB		MB96F379Y <sup>*1</sup> , MB96F379R <sup>*1</sup> ,
Package		BGA416	FPT-144P-M08, FPT-144P-M12
DMA		16 channels	7 channels
USART		10 channels	6 channels
I <sup>2</sup> C		2 channels	2 channel
A/D Converter		40 channels	22 channels
16-bit Reload Timer		6 channels + 1 channel (for PPG)	4 channels + 1 channel (for PPG)
16-bit Free-Running Timer		4 channels	2 channels
16-bit Output Compare		12 channels	6 channels
16-bit Input Capture		12 channels	8 channels
16-bit Programmable Pulse Generator		20 channels	12 channels

# MB96370 Series

Features	MB96V300	MB96(F)37x
CAN Interface	5 channels	2 channels
Stepper Motor Controller	6 channels	6 channels
External Interrupts	16 channels	8 channels
Non-Maskable Interrupt	1 channel	
Sound generator	2 channels	
LCD Controller	4 COM x 72 SEG	
Real Time Clock	1	
I/O Ports	136	118 for part number with suffix "W", 120 for part number with suffix "S"
Alarm comparator	2 channels	
External bus interface	Yes	
Chip select	6 signal	
Clock output function	2 channels	
Low voltage reset	Yes	
On-chip RC-oscillator	Yes	

\*1: These devices are under development and specification is preliminary. These products under development may change its specification without notice.

# MB96370 Series

## ■ BLOCK DIAGRAM

Block diagram of MB96(F)37x

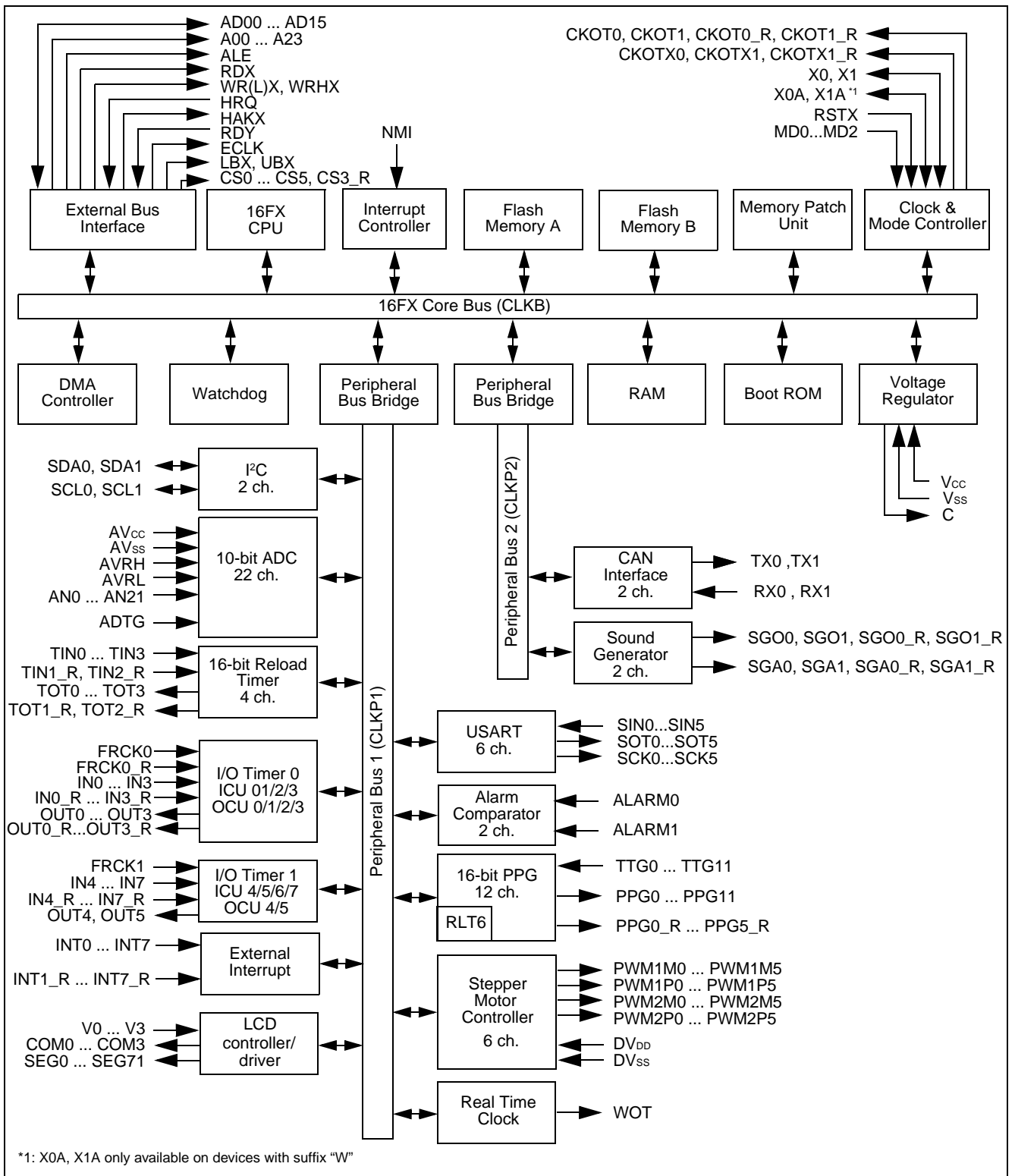



## PIN ASSIGNMENTS

### Pin assignment of MB96(F)37x

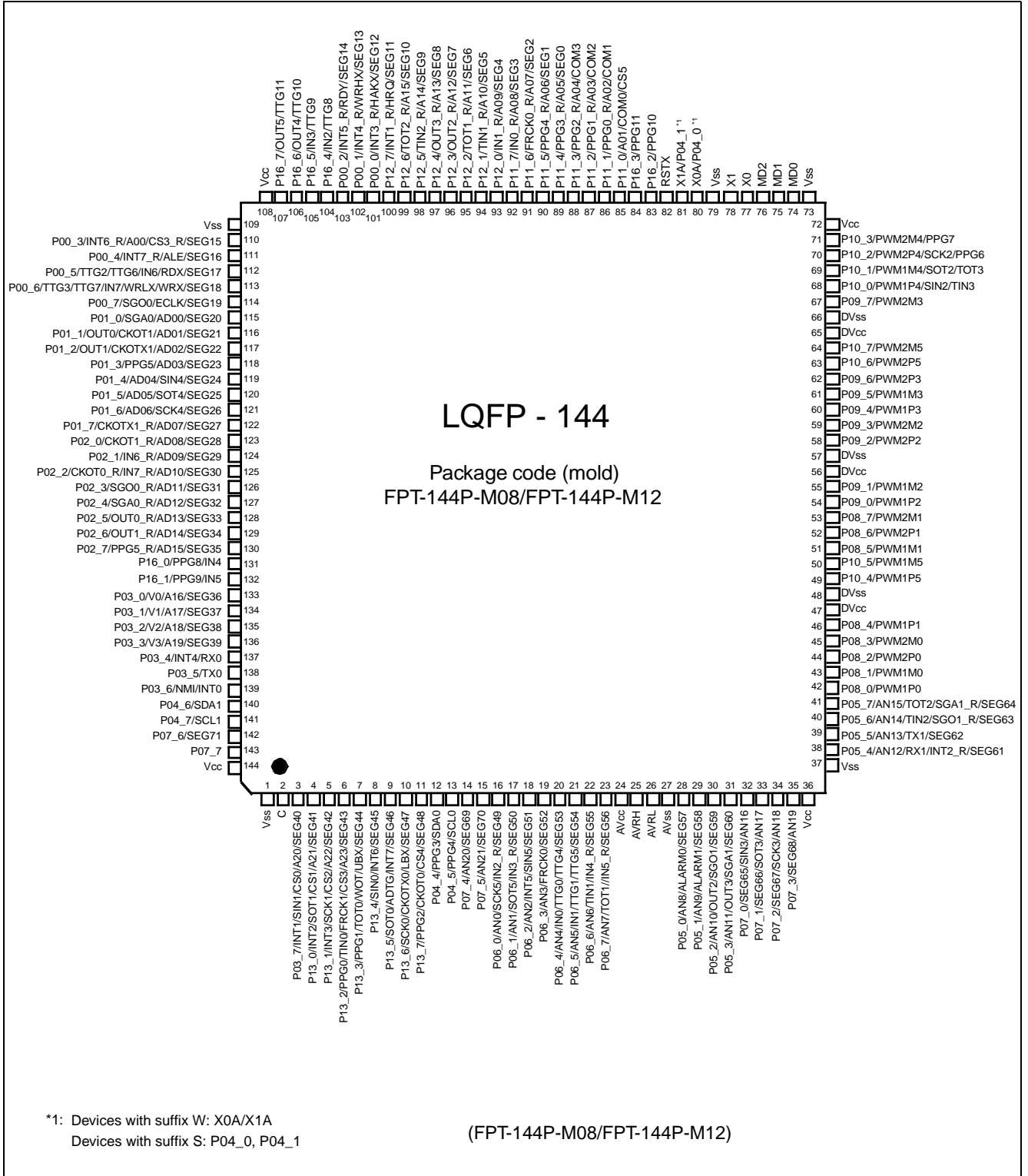

# MB96370 Series

## ■ PIN FUNCTION DESCRIPTION

### Pin Function description (1 of 3)

Pin name	Feature	Description
ADn	External bus	External bus interface (non multiplexed mode) data input/output. External bus interface (multiplexed mode) address output and data input/output
ADTG	ADC	A/D converter trigger input
ALARMn	Alarm comparator	Alarm Comparator n input
ALE	External bus	External bus Address Latch Enable output
An	External bus	External bus non-multiplexed address output
ANn	ADC	A/D converter channel n input
AV <sub>cc</sub>	Supply	Analog circuits power supply
AVRH	ADC	A/D converter high reference voltage input
AVRL	ADC	A/D converter low reference voltage input
AV <sub>ss</sub>	Supply	Analog circuits power supply
C	Voltage regulator	Internally regulated power supply stabilization capacitor pin
CKOTn	Clock output function	Clock Output function n output
CKOTn_R	Clock output function	Relocated Clock Output function n output
CKOTXn	Clock output function	Clock Output function n inverted output
CKOTXn_R	Clock output function	Relocated Clock Output function n inverted output
COMn	LCD	LCD COM pins
ECLK	External bus	External bus clock output
CSn	External bus	External bus chip select n output
CSn_R	External bus	Relocated External bus chip select n output
DV <sub>cc</sub>	Supply	SMC pins power supply
FRCKn	Free Running Timer	Free Running Timer n input
FRCKn_R	Free Running Timer	Relocated Free Running Timer n input
HAKX	External bus	External bus Hold Acknowledge
HRQ	External bus	External bus Hold Request
INn	ICU	Input Capture Unit n input
INn_R	ICU	Relocated Input Capture Unit n input
INTn	External Interrupt	External Interrupt n input
INTn_R	External Interrupt	Relocated External Interrupt n input

## Pin Function description (2 of 3)

Pin name	Feature	Description
LBX	External bus	External Bus Interface Lower Byte select strobe output
MDn	Core	Input pins for specifying the operating mode.
NMI	External Interrupt	Non-Maskable Interrupt input
OUTn	OCU	Output Compare Unit n waveform output
OUTn_R	OCU	Relocated Output Compare Unit n waveform output
Pxx_n	GPIO	General purpose IO
PPGn	PPG	Programmable Pulse Generator n output
PPGn_R	PPG	Relocated Programmable Pulse Generator n output
PWMn	SMC	SMC PWM high current
RDX	External bus	External bus interface read strobe output
RDY	External bus	External bus interface external wait state request input
RSTX	Core	Reset input
RXn	CAN	CAN interface n RX input
SCKn	USART	USART n serial clock input/output
SCLn	I <sup>2</sup> C	I <sup>2</sup> C interface n clock I/O input/output
SDAn	I <sup>2</sup> C	I <sup>2</sup> C interface n serial data I/O input/output
SEGn	LCD	LCD segment n
SGA	Sound Generator	SG amplitude output
SGO	Sound Generator	SG sound/tone output
SGA_R	Sound Generator	Relocated SG amplitude output
SGO_R	Sound Generator	Relocated SG sound/tone output
SINn	USART	USART n serial data input
SOTn	USART	USART n serial data output
TINn	Reload Timer	Reload Timer n event input
TINn_R	Reload Timer	Relocated Reload Timer n event input
TOTn	Reload Timer	Reload Timer n output
TOTn_R	Reload Timer	Relocated Reload Timer n output
TTGn	PPG	Programmable Pulse Generator n trigger input
TXn	CAN	CAN interface n TX output
UBX	External bus	External Bus Interface Upper Byte select strobe output

# MB96370 Series

## Pin Function description (3 of 3)

Pin name	Feature	Description
Vn	LCD	LCD voltage references
Vcc	Supply	Power supply
Vss	Supply	Power supply
WOT	RTC	Real Timer clock output
WRHX	External bus	External bus High byte write strobe output
WRLX/WRX	External bus	External bus Low byte / Word write strobe output
X0	Clock	Oscillator input
X0A	Clock	Subclock Oscillator input (only for devices with suffix "W")
X1	Clock	Oscillator output
X1A	Clock	Subclock Oscillator output (only for devices with suffix "W")

## ■ PIN CIRCUIT TYPE

### Pin circuit types (1 of 2)

FPT-144P-M08 or M12	
Pin no.	Circuit type *1
1	Supply
2	F
3 to 11	J
12, 13	N
14 to 23	K
24	Supply
25	G
26, 27	Supply
28 to 35	K
36,37	Supply
38 to 41	K
42 to 46	M
47, 48	Supply
49 to 55	M
56, 57	Supply
58 to 64	M
65, 66	Supply
67 to 71	M
72, 73	Supply
74 to 76	C
77, 78	A
79	Supply
80, 81	B *2
80, 81	H *3
82	E
83, 84	H
85 to 103	J
104 to 107	H
108, 109	Supply

# MB96370 Series

## Pin circuit types (2 of 2)

FPT-144P-M08 or M12	
Pin no.	Circuit type *1
110 to 130	J
131, 132	H
133 to 136	L
137 to 139	H
140, 141	N
142	J
143	H
144	Supply

\*1: Please refer to “■ I/O CIRCUIT TYPE” for details on the I/O circuit types

\*2: Devices with suffix “W”

\*3: Devices without suffix “W”

## ■ I/O CIRCUIT TYPE

Type	Circuit	Remarks
A		<p>High-speed oscillation circuit:</p> <ul style="list-style-type: none"> <li>• Programmable between oscillation mode (external crystal or resonator connected to X0/X1 pins) and Fast external Clock Input (FCI) mode (external clock connected to X0 pin)</li> <li>• Programmable feedback resistor = approx. <math>2 * 0.5 \text{ M}\Omega</math>. Feedback resistor is grounded in the center when the oscillator is disabled or in FCI mode</li> </ul>
B		<p>Low-speed oscillation circuit:</p> <ul style="list-style-type: none"> <li>• Programmable feedback resistor = approx. <math>2 * 5 \text{ M}\Omega</math>. Feedback resistor is grounded in the center when the oscillator is disabled</li> </ul>
C		<ul style="list-style-type: none"> <li>• Mask ROM and EVA device: CMOS Hysteresis input pin</li> <li>• Flash device: CMOS input pin</li> </ul>
E		<ul style="list-style-type: none"> <li>• CMOS Hysteresis input pin</li> <li>• Pull-up resistor value: approx. <math>50 \text{ k}\Omega</math></li> </ul>

# MB96370 Series

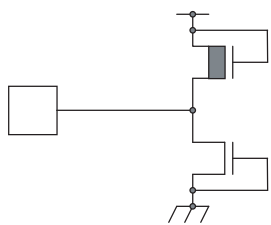
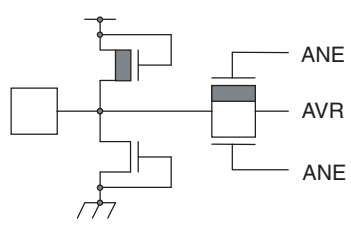
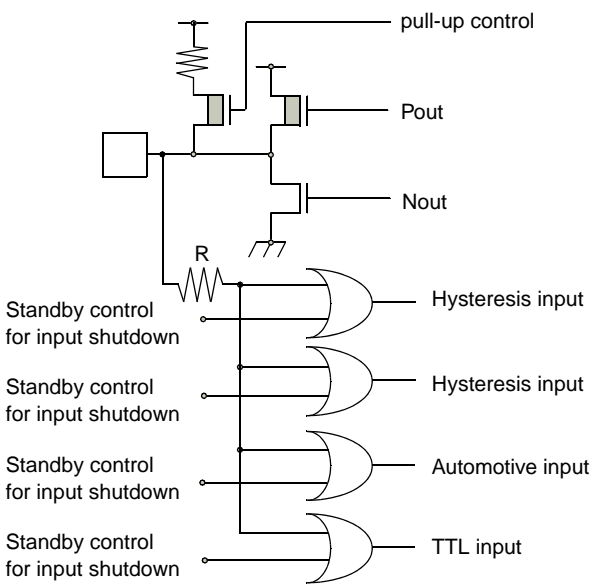
Type	Circuit	Remarks
F		<ul style="list-style-type: none"> <li>• Power supply input protection circuit</li> </ul>
G		<ul style="list-style-type: none"> <li>• A/D converter ref+ (AVRH/AVRH2) power supply input pin with protection circuit</li> <li>• Flash devices do not have a protection circuit against VCC for pins AVRH/AVRH2</li> <li>• Devices without AVRH reference switch do not have an analog switch for the AVRL pin</li> </ul>
H	 <p>pull-up control</p> <p>Pout</p> <p>Nout</p> <p>R</p> <p>Standby control for input shutdown</p> <p>Hysteresis input</p> <p>Hysteresis input</p> <p>Automotive input</p> <p>TTL input</p>	<ul style="list-style-type: none"> <li>• CMOS level output (programmable <math>I_{OL} = 5\text{mA}</math>, <math>I_{OH} = -5\text{mA}</math> and <math>I_{OL} = 2\text{mA}</math>, <math>I_{OH} = -2\text{mA}</math>)</li> <li>• 2 different CMOS hysteresis inputs with input shutdown function</li> <li>• Automotive input with input shutdown function</li> <li>• TTL input with input shutdown function</li> <li>• Programmable pull-up resistor: <math>50\text{k}\Omega</math> approx.</li> </ul>

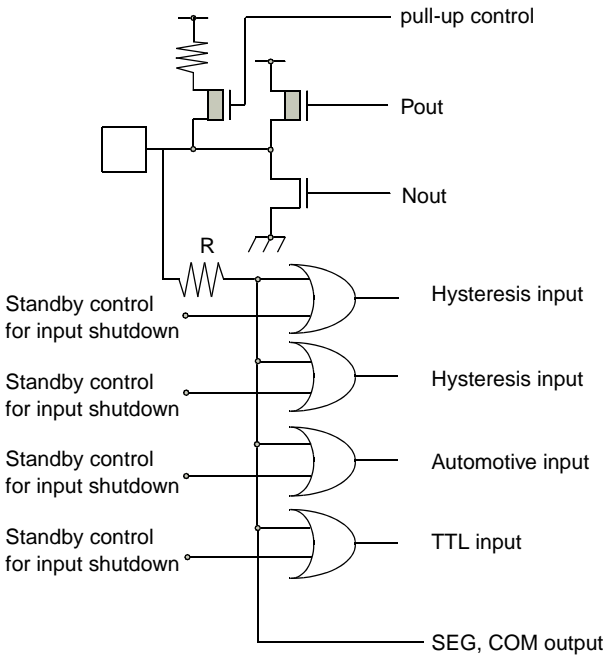
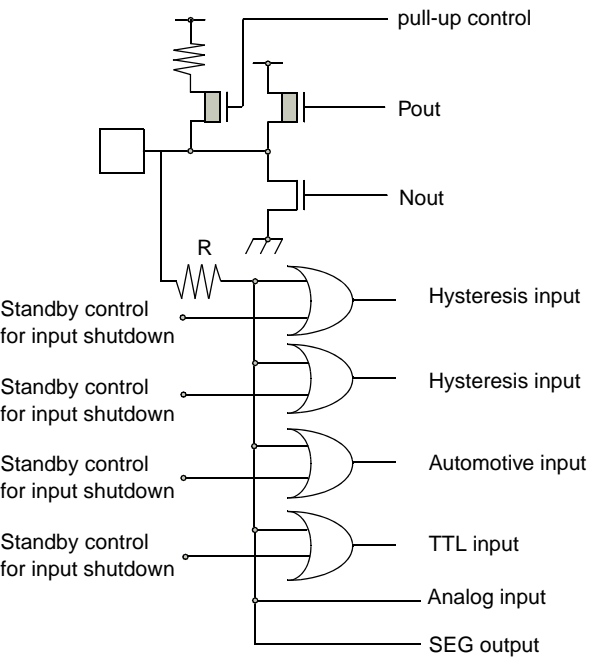

Type	Circuit	Remarks
J	 <p>The diagram for Type J shows a pull-up control circuit with a resistor R. It includes two CMOS outputs, Pout and Nout. The input stage consists of four OR gates. The top two are labeled 'Hysteresis input', the middle one 'Automotive input', and the bottom one 'TTL input'. Each OR gate has a 'Standby control for input shutdown' input. The output of the bottom OR gate is labeled 'SEG, COM output'.</p>	<ul style="list-style-type: none"> <li>• CMOS level output (programmable <math>I_{OL} = 5\text{mA}</math>, <math>I_{OH} = -5\text{mA}</math> and <math>I_{OL} = 2\text{mA}</math>, <math>I_{OH} = -2\text{mA}</math>)</li> <li>• 2 different CMOS hysteresis inputs with input shutdown function</li> <li>• Automotive input with input shutdown function</li> <li>• TTL input with input shutdown function</li> <li>• Programmable pull-up resistor: <math>50\text{k}\Omega</math> approx.</li> <li>• SEG or COM output</li> </ul>
K	 <p>The diagram for Type K is similar to Type J but includes an 'Analog input' at the bottom. The OR gates are labeled 'Hysteresis input', 'Hysteresis input', 'Automotive input', and 'TTL input'. Each has a 'Standby control for input shutdown' input. The output of the bottom OR gate is labeled 'SEG output'.</p>	<ul style="list-style-type: none"> <li>• CMOS level output (programmable <math>I_{OL} = 5\text{mA}</math>, <math>I_{OH} = -5\text{mA}</math> and <math>I_{OL} = 2\text{mA}</math>, <math>I_{OH} = -2\text{mA}</math>)</li> <li>• 2 different CMOS hysteresis inputs with input shutdown function</li> <li>• Automotive input with input shutdown function</li> <li>• TTL input with input shutdown function.</li> <li>• Programmable pull-up resistor: <math>50\text{k}\Omega</math> approx.</li> <li>• Analog input</li> <li>• SEG output</li> </ul>

# MB96370 Series

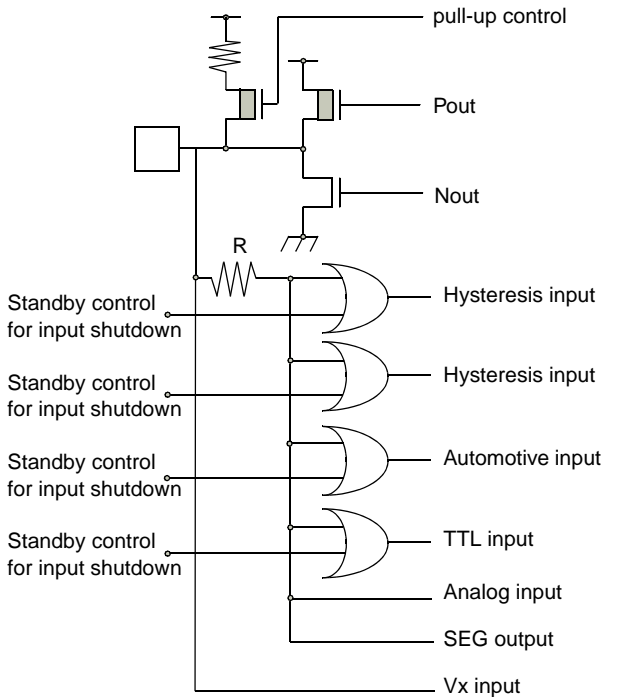
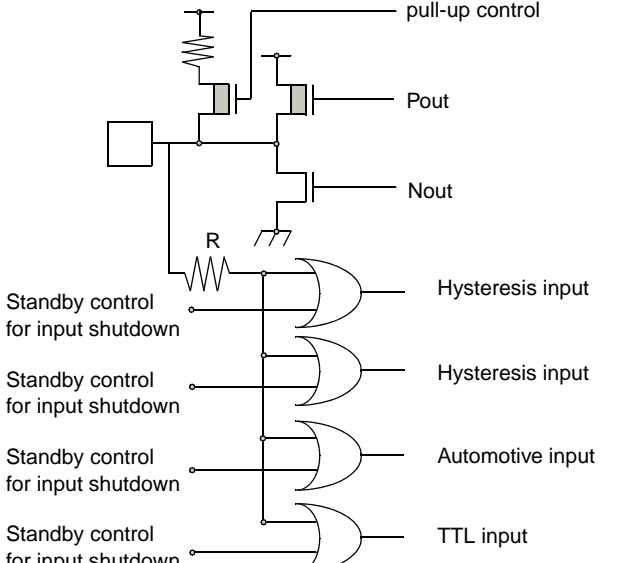
Type	Circuit	Remarks
L	 <p>The diagram for Type L shows a pull-up control circuit with a resistor and a PMOS transistor. The output is connected to a PMOS transistor (Pout) and an NMOS transistor (Nout). The input is connected to a resistor (R) and a PMOS transistor. The input is also connected to four OR gates, each with a standby control for input shutdown. The outputs of these OR gates are labeled Hysteresis input, Hysteresis input, Automotive input, and TTL input. The input is also connected to an Analog input and a SEG output. The input is also connected to a Vx input.</p>	<ul style="list-style-type: none"> <li>• CMOS level output (programmable <math>I_{OL} = 5\text{mA}</math>, <math>I_{OH} = -5\text{mA}</math> and <math>I_{OL} = 2\text{mA}</math>, <math>I_{OH} = -2\text{mA}</math>)</li> <li>• 2 different CMOS hysteresis inputs with input shutdown function</li> <li>• Automotive input with input shutdown function</li> <li>• TTL input with input shutdown function</li> <li>• Programmable pull-up resistor: <math>50\text{k}\Omega</math> approx.</li> <li>• Analog input</li> <li>• Vx input</li> <li>• SEG output</li> </ul>
M	 <p>The diagram for Type M shows a pull-up control circuit with a resistor and a PMOS transistor. The output is connected to a PMOS transistor (Pout) and an NMOS transistor (Nout). The input is connected to a resistor (R) and a PMOS transistor. The input is also connected to three OR gates, each with a standby control for input shutdown. The outputs of these OR gates are labeled Hysteresis input, Hysteresis input, and Automotive input. The input is also connected to a TTL input.</p>	<ul style="list-style-type: none"> <li>• CMOS level output (programmable <math>I_{OL} = 5\text{mA}</math>, <math>I_{OH} = -5\text{mA}</math> and <math>I_{OL} = 2\text{mA}</math>, <math>I_{OH} = -2\text{mA}</math>, <math>I_{OL} = 30\text{mA}</math>, <math>I_{OH} = -30\text{mA}</math>)</li> <li>• 2 different CMOS hysteresis inputs with input shutdown function</li> <li>• Automotive input with input shutdown function</li> <li>• TTL input with input shutdown function</li> <li>• Programmable pull-up resistor: <math>50\text{k}\Omega</math> approx.</li> </ul>

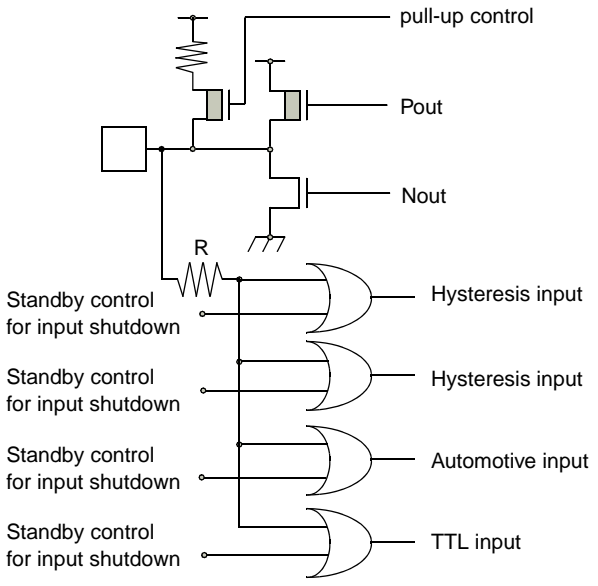
Type	Circuit	Remarks
N	 <p>The circuit diagram shows an input stage with a pull-up resistor R connected to a pull-up control input. The input signal is connected to a network of four inputs: two Hysteresis inputs, an Automotive input, and a TTL input. Each of these four inputs has a corresponding standby control for input shutdown. The output stage consists of a PMOS transistor (Pout) and an NMOS transistor (Nout) connected to ground.</p>	<ul style="list-style-type: none"> <li>• CMOS level output (<math>I_{OL} = 3mA</math>, <math>I_{OH} = -3mA</math>)</li> <li>• 2 different CMOS hysteresis inputs with input shutdown function</li> <li>• Automotive input with input shutdown function</li> <li>• TTL input with input shutdown function</li> <li>• Programmable pull-up resistor: <math>50k\Omega</math> approx.</li> </ul>

# MB96370 Series

## ■ MEMORY MAP

MB96V300B		MB96(F)37x	
FF:FFF <sub>H</sub>	Emulation ROM		USER ROM / External Bus <sup>*4</sup>
DE:000 <sub>H</sub>	External Bus		External Bus
10:000 <sub>H</sub>	Boot-ROM		Boot-ROM
0F:E00 <sub>H</sub>	Reserved		Reserved
0E:000 <sub>H</sub>	External RAM		Reserved
02:000 <sub>H</sub>	Internal RAM bank 1	RAMEND <sup>1*2</sup> RAMSTART <sup>1*2</sup>	Internal RAM bank 1
01:000 <sub>H</sub>	ROM/RAM MIRROR		ROM/RAM MIRROR
00:800 <sub>H</sub>	Internal RAM bank 0	RAMSTART <sup>0*2</sup>	Internal RAM bank 0
	External Bus		Reserved
RAMSTART <sup>0*3</sup>	External Bus		External Bus
00:0C0 <sub>H</sub>	Peripherals		Peripherals
00:038 <sub>H</sub>	GPR <sup>*1</sup>		GPR <sup>*1</sup>
00:018 <sub>H</sub>	DMA		DMA
00:010 <sub>H</sub>	External Bus		External Bus
00:00F <sub>H</sub>	Peripheral		Peripheral
00:000 <sub>H</sub>			

RAM availability depending on the device

External Bus end address<sup>\*2</sup>

\*1: Unused GPR banks can be used as RAM area  
 \*2: For External Bus end address and RAMSTART/END addresses, please refer to the table on the next page.  
 \*3: For EVA device, RAMSTART0 depends on the configuration of the emulated device.  
 \*4: For details about USER ROM area, see the ■ USER ROM MEMORY MAP FOR FLASH DEVICES on the following pages.

The External Bus area and DMA area are only available if the device contains the corresponding resource.  
 The available RAM and ROM area depends on the device.

## ■ RAMSTART/END AND EXTERNAL BUS END ADDRESSES

Devices	Bank 0 RAM size	Bank 1 RAM size	External Bus end address	RAMSTART0	RAMSTART1	RAMEND1
MB96F378	28KByte	-	00:11FF <sub>H</sub>	00:1240 <sub>H</sub>	-	-
MB96F379	28KByte	4KByte	00:11FF <sub>H</sub>	00:1240 <sub>H</sub>	01:8000 <sub>H</sub>	01:8FFF <sub>H</sub>

# MB96370 Series

## ■ USER ROM MEMORY MAP FOR FLASH DEVICES

Alternative mode CPU address	Flash memory mode address	MB96F378T MB96F378H	MB96F379R MB96F379Y		
		Flash size 576kByte	Flash size 832kByte		
FF:FFFF <sub>H</sub> FF:0000 <sub>H</sub>	3F:FFFF <sub>H</sub> 3F:0000 <sub>H</sub>	S39 - 64K	S39 - 64K	Flash A	
FE:FFFF <sub>H</sub> FE:0000 <sub>H</sub>	3E:FFFF <sub>H</sub> 3E:0000 <sub>H</sub>	S38 - 64K	S38 - 64K		
FD:FFFF <sub>H</sub> FD:0000 <sub>H</sub>	3D:FFFF <sub>H</sub> 3D:0000 <sub>H</sub>	S37 - 64K	S37 - 64K		
FC:FFFF <sub>H</sub> FC:0000 <sub>H</sub>	3C:FFFF <sub>H</sub> 3C:0000 <sub>H</sub>	S36 - 64K	S36 - 64K		
FB:FFFF <sub>H</sub> FB:0000 <sub>H</sub>	3B:FFFF <sub>H</sub> 3B:0000 <sub>H</sub>	S35 - 64K	S35 - 64K		
FA:FFFF <sub>H</sub> FA:0000 <sub>H</sub>	3A:FFFF <sub>H</sub> 3A:0000 <sub>H</sub>	S34 - 64K	S34 - 64K		
F9:FFFF <sub>H</sub> F9:0000 <sub>H</sub>	39:FFFF <sub>H</sub> 39:0000 <sub>H</sub>	S33 - 64K	S33 - 64K		
F8:FFFF <sub>H</sub> F8:0000 <sub>H</sub>	38:FFFF <sub>H</sub> 38:0000 <sub>H</sub>	S32 - 64K	S32 - 64K		
F7:FFFF <sub>H</sub> F7:0000 <sub>H</sub>	37:FFFF <sub>H</sub> 37:0000 <sub>H</sub>	External bus	S31 - 64K		Flash B
F6:FFFF <sub>H</sub> F6:0000 <sub>H</sub>	36:FFFF <sub>H</sub> 36:0000 <sub>H</sub>		S30 - 64K		
F5:FFFF <sub>H</sub> F5:0000 <sub>H</sub>	35:FFFF <sub>H</sub> 35:0000 <sub>H</sub>		S29 - 64K		
F4:FFFF <sub>H</sub> F4:0000 <sub>H</sub>	34:FFFF <sub>H</sub> 34:0000 <sub>H</sub>		S28 - 64K		
F3:FFFF <sub>H</sub> F3:0000 <sub>H</sub>	33:FFFF <sub>H</sub> 33:0000 <sub>H</sub>		External bus	External bus	
F2:FFFF <sub>H</sub> F2:0000 <sub>H</sub>	32:FFFF <sub>H</sub> 32:0000 <sub>H</sub>				
F1:FFFF <sub>H</sub> F1:0000 <sub>H</sub>	31:FFFF <sub>H</sub> 31:0000 <sub>H</sub>				
F0:FFFF <sub>H</sub> F0:0000 <sub>H</sub>	30:FFFF <sub>H</sub> 30:0000 <sub>H</sub>				
E0:FFFF <sub>H</sub>					
E0:0000 <sub>H</sub> DF:FFFF <sub>H</sub>					Reserved
DF:8000 <sub>H</sub> DF:7FFF <sub>H</sub> DF:6000 <sub>H</sub>	1F:7FFF <sub>H</sub> 1F:6000 <sub>H</sub>	SA3 - 8K	SA3 - 8K	Flash A	
DF:5FFF <sub>H</sub> DF:4000 <sub>H</sub>	1F:5FFF <sub>H</sub> 1F:4000 <sub>H</sub>	SA2 - 8K	SA2 - 8K		
DF:3FFF <sub>H</sub> DF:2000 <sub>H</sub>	1F:3FFF <sub>H</sub> 1F:2000 <sub>H</sub>	SA1 - 8K	SA1 - 8K		
DF:1FFF <sub>H</sub> DF:0000 <sub>H</sub>	1F:1FFF <sub>H</sub> 1F:0000 <sub>H</sub>	SA0 - 8K *1	SA0 - 8K *1		
DE:FFFF <sub>H</sub>		Reserved	Reserved		
DE:8000 <sub>H</sub> DE:7FFF <sub>H</sub> DE:6000 <sub>H</sub>	1E:7FFF <sub>H</sub> 1E:6000 <sub>H</sub>	SB3 - 8K	SB3 - 8K	Flash B	
DE:5FFF <sub>H</sub> DE:4000 <sub>H</sub>	1E:5FFF <sub>H</sub> 1E:4000 <sub>H</sub>	SB2 - 8K	SB2 - 8K		
DE:3FFF <sub>H</sub> DE:2000 <sub>H</sub>	1E:3FFF <sub>H</sub> 1E:2000 <sub>H</sub>	SB1 - 8K	SB1 - 8K		
DE:1FFF <sub>H</sub> DE:0000 <sub>H</sub>	1E:1FFF <sub>H</sub> 1E:0000 <sub>H</sub>	SB0 - 8K *2	SB0 - 8K *2		

\*1: Sector SA0 contains the ROM Configuration Block RCBA at CPU address DF:0000<sub>H</sub> - DF:007F<sub>H</sub>  
 \*2: Sector SB0 contains the ROM Configuration Block RCBB at CPU address DE:0000<sub>H</sub> - DE:002F<sub>H</sub>

## ■ SERIAL PROGRAMMING COMMUNICATION INTERFACE

USART pins for Flash serial programming (MD[2:0] = 010)

MB96F37x		
Pin number	USART Number	Normal function
LQFP-144		
8	USART0	SIN0
9		SOT0
10		SCK0
3	USART1	SIN1
4		SOT1
5		SCK1
68	USART2	SIN2
69		SOT2
70		SCK2
32	USART3	SIN3
33		SOT3
34		SCK3

Note: If a Flash programmer and its software needs to use a handshaking pin, Fujitsu suggests to the tool vendor to support at least port P00\_1 on pin 102.

If handshaking is used by the tool but P00\_1 is not available in customer's application, Fujitsu suggests to the customer to check the tool manual or to contact the tool vendor for alternative handshaking pins.

# MB96370 Series

## ■ I/O MAP

### I/O map MB96(F)37x (1 of 34)

Address	Register	Abbreviation 8-bit access	Abbreviation 16-bit access	Access
000000H	I/O Port P00 - Port Data Register	PDR00		R/W
000001H	I/O Port P01 - Port Data Register	PDR01		R/W
000002H	I/O Port P02 - Port Data Register	PDR02		R/W
000003H	I/O Port P03 - Port Data Register	PDR03		R/W
000004H	I/O Port P04 - Port Data Register	PDR04		R/W
000005H	I/O Port P05 - Port Data Register	PDR05		R/W
000006H	I/O Port P06 - Port Data Register	PDR06		R/W
000007H	I/O Port P07 - Port Data Register	PDR07		R/W
000008H	I/O Port P08 - Port Data Register	PDR08		R/W
000009H	I/O Port P09 - Port Data Register	PDR09		R/W
00000AH	I/O Port P10 - Port Data Register	PDR10		R/W
00000BH	I/O Port P11 - Port Data Register	PDR11		R/W
00000CH	I/O Port P12 - Port Data Register	PDR12		R/W
00000DH	I/O Port P13 - Port Data Register	PDR13		R/W
00000EH- 00000FH	Reserved			-
000010H	I/O Port P16 - Port Data Register	PDR16		R/W
000011H- 000017H	Reserved			-
000018H	ADC0 - Control Status register Low	ADCSL	ADCS	R/W
000019H	ADC0 - Control Status register High	ADCSH		R/W
00001AH	ADC0 - Data Register Low	ADCRL	ADCR	R
00001BH	ADC0 - Data Register High	ADCRH		R
00001CH	ADC0 - Setting Register		ADSR	R/W
00001DH	ADC0 - Setting Register			R/W
00001EH	ADC0 - Extended Configuration Register	ADECR		R/W
00001FH	Reserved			-
000020H	FRT0 - Data register of free-running timer		TCDT0	R/W
000021H	FRT0 - Data register of free-running timer			R/W



## I/O map MB96(F)37x (2 of 34)

Address	Register	Abbreviation 8-bit access	Abbreviation 16-bit access	Access
000022 <sub>H</sub>	FRT0 - Control status register of free-running timer Low	TCCSL0	TCCS0	R/W
000023 <sub>H</sub>	FRT0 - Control status register of free-running timer High	TCCSH0		R/W
000024 <sub>H</sub>	FRT1 - Data register of free-running timer		TCDT1	R/W
000025 <sub>H</sub>	FRT1 - Data register of free-running timer			R/W
000026 <sub>H</sub>	FRT1 - Control status register of free-running timer Low	TCCSL1	TCCS1	R/W
000027 <sub>H</sub>	FRT1 - Control status register of free-running timer High	TCCSH1		R/W
000028 <sub>H</sub>	OCU0 - Output Compare Control Status	OCS0		R/W
000029 <sub>H</sub>	OCU1 - Output Compare Control Status	OCS1		R/W
00002A <sub>H</sub>	OCU0 - Compare Register		OCCP0	R/W
00002B <sub>H</sub>	OCU0 - Compare Register			R/W
00002C <sub>H</sub>	OCU1 - Compare Register		OCCP1	R/W
00002D <sub>H</sub>	OCU1 - Compare Register			R/W
00002E <sub>H</sub>	OCU2 - Output Compare Control Status	OCS2		R/W
00002F <sub>H</sub>	OCU3 - Output Compare Control Status	OCS3		R/W
000030 <sub>H</sub>	OCU2 - Compare Register		OCCP2	R/W
000031 <sub>H</sub>	OCU2 - Compare Register			R/W
000032 <sub>H</sub>	OCU3 - Compare Register		OCCP3	R/W
000033 <sub>H</sub>	OCU3 - Compare Register			R/W
000034 <sub>H</sub>	OCU4 - Output Compare Control Status	OCS4		R/W
000035 <sub>H</sub>	OCU5 - Output Compare Control Status	OCS5		R/W
000036 <sub>H</sub>	OCU4 - Compare Register		OCCP4	R/W
000037 <sub>H</sub>	OCU4 - Compare Register			R/W
000038 <sub>H</sub>	OCU5 - Compare Register		OCCP5	R/W
000039 <sub>H</sub>	OCU5 - Compare Register			R/W
00003A <sub>H</sub> - 00003F <sub>H</sub>	Reserved			-
000040 <sub>H</sub>	ICU0/ICU1 - Control Status Register	ICS01		R/W
000041 <sub>H</sub>	ICU0/ICU1 - Edge register	ICE01		R/W

# MB96370 Series

## I/O map MB96(F)37x (3 of 34)

Address	Register	Abbreviation 8-bit access	Abbreviation 16-bit access	Access
000042 <sub>H</sub>	ICU0 - Capture Register Low	IPCPL0	IPCP0	R
000043 <sub>H</sub>	ICU0 - Capture Register High	IPCPH0		R
000044 <sub>H</sub>	ICU1 - Capture Register Low	IPCPL1	IPCP1	R
000045 <sub>H</sub>	ICU1 - Capture Register High	IPCPH1		R
000046 <sub>H</sub>	ICU2/ICU3 - Control Status Register	ICS23		R/W
000047 <sub>H</sub>	ICU2/ICU3 - Edge register	ICE23		R/W
000048 <sub>H</sub>	ICU2 - Capture Register Low	IPCPL2	IPCP2	R
000049 <sub>H</sub>	ICU2 - Capture Register High	IPCPH2		R
00004A <sub>H</sub>	ICU3 - Capture Register Low	IPCPL3	IPCP3	R
00004B <sub>H</sub>	ICU3 - Capture Register High	IPCPH3		R
00004C <sub>H</sub>	ICU4/ICU5 - Control Status Register	ICS45		R/W
00004D <sub>H</sub>	ICU4/ICU5 - Edge register	ICE45		R/W
00004E <sub>H</sub>	ICU4 - Capture Register Low	IPCPL4	IPCP4	R
00004F <sub>H</sub>	ICU4 - Capture Register High	IPCPH4		R
000050 <sub>H</sub>	ICU5 - Capture Register Low	IPCPL5	IPCP5	R
000051 <sub>H</sub>	ICU5 - Capture Register High	IPCPH5		R
000052 <sub>H</sub>	ICU6/ICU7 - Control Status Register	ICS67		R/W
000053 <sub>H</sub>	ICU6/ICU7 - Edge register	ICE67		R/W
000054 <sub>H</sub>	ICU6 - Capture Register Low	IPCPL6	IPCP6	R
000055 <sub>H</sub>	ICU6 - Capture Register High	IPCPH6		R
000056 <sub>H</sub>	ICU7 - Capture Register Low	IPCPL7	IPCP7	R
000057 <sub>H</sub>	ICU7 - Capture Register High	IPCPH7		R
000058 <sub>H</sub>	EXTINT0 - External Interrupt Enable Register	ENIR0		R/W
000059 <sub>H</sub>	EXTINT0 - External Interrupt Interrupt request Register	EIRR0		R/W
00005A <sub>H</sub>	EXTINT0 - External Interrupt Level Select Low	ELVRL0	ELVR0	R/W
00005B <sub>H</sub>	EXTINT0 - External Interrupt Level Select High	ELVRH0		R/W
00005C <sub>H</sub> - 00005F <sub>H</sub>	Reserved			-
000060 <sub>H</sub>	RLT0 - Timer Control Status Register Low	TMCSRL0	TMCSR0	R/W
000061 <sub>H</sub>	RLT0 - Timer Control Status Register High	TMCSRH0		R/W

## I/O map MB96(F)37x (4 of 34)

Address	Register	Abbreviation 8-bit access	Abbreviation 16-bit access	Access
000062 <sub>H</sub>	RLT0 - Reload Register - for writing		TMRLR0	W
000062 <sub>H</sub>	RLT0 - Reload Register - for reading		TMR0	R
000063 <sub>H</sub>	RLT0 - Reload Register - for writing			W
000063 <sub>H</sub>	RLT0 - Reload Register - for reading			R
000064 <sub>H</sub>	RLT1 - Timer Control Status Register Low	TMCSRL1	TMCSR1	R/W
000065 <sub>H</sub>	RLT1 - Timer Control Status Register High	TMCSRH1		R/W
000066 <sub>H</sub>	RLT1 - Reload Register - for writing		TMRLR1	W
000066 <sub>H</sub>	RLT1 - Reload Register - for reading		TMR1	R
000067 <sub>H</sub>	RLT1 - Reload Register - for writing			W
000067 <sub>H</sub>	RLT1 - Reload Register - for reading			R
000068 <sub>H</sub>	RLT2 - Timer Control Status Register Low	TMCSRL2	TMCSR2	R/W
000069 <sub>H</sub>	RLT2 - Timer Control Status Register High	TMCSRH2		R/W
00006A <sub>H</sub>	RLT2 - Reload Register - for writing		TMRLR2	W
00006A <sub>H</sub>	RLT2 - Reload Register - for reading		TMR2	R
00006B <sub>H</sub>	RLT2 - Reload Register - for writing			W
00006B <sub>H</sub>	RLT2 - Reload Register - for reading			R
00006C <sub>H</sub>	RLT3 - Timer Control Status Register Low	TMCSRL3	TMCSR3	R/W
00006D <sub>H</sub>	RLT3 - Timer Control Status Register High	TMCSRH3		R/W
00006E <sub>H</sub>	RLT3 - Reload Register - for writing		TMRLR3	W
00006E <sub>H</sub>	RLT3 - Reload Register - for reading		TMR3	R
00006F <sub>H</sub>	RLT3 - Reload Register - for writing			W
00006F <sub>H</sub>	RLT3 - Reload Register - for reading			R
000070 <sub>H</sub>	RLT6 - Timer Control Status Register Low (dedic. RLT for PPG)	TMCSRL6	TMCSR6	R/W
000071 <sub>H</sub>	RLT6 - Timer Control Status Register High (dedic. RLT for PPG)	TMCSRH6		R/W
000072 <sub>H</sub>	RLT6 - Reload Register (dedic. RLT for PPG) - for writing		TMRLR6	W
000072 <sub>H</sub>	RLT6 - Reload Register (dedic. RLT for PPG) - for reading		TMR6	R
000073 <sub>H</sub>	RLT6 - Reload Register (dedic. RLT for PPG) - for writing			W

# MB96370 Series

## I/O map MB96(F)37x (5 of 34)

Address	Register	Abbreviation 8-bit access	Abbreviation 16-bit access	Access
000073 <sub>H</sub>	RLT6 - Reload Register (dedic. RLT for PPG) - for reading			R
000074 <sub>H</sub>	PPG3-PPG0 - General Control register 1 Low	GCN1L0	GCN10	R/W
000075 <sub>H</sub>	PPG3-PPG0 - General Control register 1 High	GCN1H0		R/W
000076 <sub>H</sub>	PPG3-PPG0 - General Control register 2 Low	GCN2L0	GCN20	R/W
000077 <sub>H</sub>	PPG3-PPG0 - General Control register 2 High	GCN2H0		R/W
000078 <sub>H</sub>	PPG0 - Timer register		PTMR0	R
000079 <sub>H</sub>	PPG0 - Timer register			R
00007A <sub>H</sub>	PPG0 - Period setting register		PCSR0	W
00007B <sub>H</sub>	PPG0 - Period setting register			W
00007C <sub>H</sub>	PPG0 - Duty cycle register		PDUT0	W
00007D <sub>H</sub>	PPG0 - Duty cycle register			W
00007E <sub>H</sub>	PPG0 - Control status register Low	PCNL0	PCN0	R/W
00007F <sub>H</sub>	PPG0 - Control status register High	PCNH0		R/W
000080 <sub>H</sub>	PPG1 - Timer register		PTMR1	R
000081 <sub>H</sub>	PPG1 - Timer register			R
000082 <sub>H</sub>	PPG1 - Period setting register		PCSR1	W
000083 <sub>H</sub>	PPG1 - Period setting register			W
000084 <sub>H</sub>	PPG1 - Duty cycle register		PDUT1	W
000085 <sub>H</sub>	PPG1 - Duty cycle register			W
000086 <sub>H</sub>	PPG1 - Control status register Low	PCNL1	PCN1	R/W
000087 <sub>H</sub>	PPG1 - Control status register High	PCNH1		R/W
000088 <sub>H</sub>	PPG2 - Timer register		PTMR2	R
000089 <sub>H</sub>	PPG2 - Timer register			R
00008A <sub>H</sub>	PPG2 - Period setting register		PCSR2	W
00008B <sub>H</sub>	PPG2 - Period setting register			W
00008C <sub>H</sub>	PPG2 - Duty cycle register		PDUT2	W
00008D <sub>H</sub>	PPG2 - Duty cycle register			W
00008E <sub>H</sub>	PPG2 - Control status register Low	PCNL2	PCN2	R/W
00008F <sub>H</sub>	PPG2 - Control status register High	PCNH2		R/W

## I/O map MB96(F)37x (6 of 34)

Address	Register	Abbreviation 8-bit access	Abbreviation 16-bit access	Access
000090 <sub>H</sub>	PPG3 - Timer register		PTMR3	R
000091 <sub>H</sub>	PPG3 - Timer register			R
000092 <sub>H</sub>	PPG3 - Period setting register		PCSR3	W
000093 <sub>H</sub>	PPG3 - Period setting register			W
000094 <sub>H</sub>	PPG3 - Duty cycle register		PDUT3	W
000095 <sub>H</sub>	PPG3 - Duty cycle register			W
000096 <sub>H</sub>	PPG3 - Control status register Low	PCNL3	PCN3	R/W
000097 <sub>H</sub>	PPG3 - Control status register High	PCNH3		R/W
000098 <sub>H</sub>	PPG7-PPG4 - General Control register 1 Low	GCN1L1	GCN11	R/W
000099 <sub>H</sub>	PPG7-PPG4 - General Control register 1 High	GCN1H1		R/W
00009A <sub>H</sub>	PPG7-PPG4 - General Control register 2 Low	GCN2L1	GCN21	R/W
00009B <sub>H</sub>	PPG7-PPG4 - General Control register 2 High	GCN2H1		R/W
00009C <sub>H</sub>	PPG4 - Timer register		PTMR4	R
00009D <sub>H</sub>	PPG4 - Timer register			R
00009E <sub>H</sub>	PPG4 - Period setting register		PCSR4	W
00009F <sub>H</sub>	PPG4 - Period setting register			W
0000A0 <sub>H</sub>	PPG4 - Duty cycle register		PDUT4	W
0000A1 <sub>H</sub>	PPG4 - Duty cycle register			W
0000A2 <sub>H</sub>	PPG4 - Control status register Low	PCNL4	PCN4	R/W
0000A3 <sub>H</sub>	PPG4 - Control status register High	PCNH4		R/W
0000A4 <sub>H</sub>	PPG5 - Timer register		PTMR5	R
0000A5 <sub>H</sub>	PPG5 - Timer register			R
0000A6 <sub>H</sub>	PPG5 - Period setting register		PCSR5	W
0000A7 <sub>H</sub>	PPG5 - Period setting register			W
0000A8 <sub>H</sub>	PPG5 - Duty cycle register		PDUT5	W
0000A9 <sub>H</sub>	PPG5 - Duty cycle register			W
0000AA <sub>H</sub>	PPG5 - Control status register Low	PCNL5	PCN5	R/W
0000AB <sub>H</sub>	PPG5 - Control status register High	PCNH5		R/W
0000AC <sub>H</sub>	I2C0 - Bus Status Register	IBSR0		R
0000AD <sub>H</sub>	I2C0 - Bus Control Register	IBCR0		R/W

# MB96370 Series

## I/O map MB96(F)37x (7 of 34)

Address	Register	Abbreviation 8-bit access	Abbreviation 16-bit access	Access
0000AE <sub>H</sub>	I2C0 - Ten bit Slave address Register Low	ITBAL0	ITBA0	R/W
0000AF <sub>H</sub>	I2C0 - Ten bit Slave address Register High	ITBAH0		R/W
0000B0 <sub>H</sub>	I2C0 - Ten bit Address mask Register Low	ITMKL0	ITMK0	R/W
0000B1 <sub>H</sub>	I2C0 - Ten bit Address mask Register High	ITMKH0		R/W
0000B2 <sub>H</sub>	I2C0 - Seven bit Slave address Register	ISBA0		R/W
0000B3 <sub>H</sub>	I2C0 - Seven bit Address mask Register	ISMK0		R/W
0000B4 <sub>H</sub>	I2C0 - Data Register	IDAR0		R/W
0000B5 <sub>H</sub>	I2C0 - Clock Control Register	ICCR0		R/W
0000B6 <sub>H</sub>	I2C1 - Bus Status Register	IBSR1		R
0000B7 <sub>H</sub>	I2C1 - Bus Control Register	IBCR1		R/W
0000B8 <sub>H</sub>	I2C1 - Ten bit Slave address Register Low	ITBAL1	ITBA1	R/W
0000B9 <sub>H</sub>	I2C1 - Ten bit Slave address Register High	ITBAH1		R/W
0000BA <sub>H</sub>	I2C1 - Ten bit Address mask Register Low	ITMKL1	ITMK1	R/W
0000BB <sub>H</sub>	I2C1 - Ten bit Address mask Register High	ITMKH1		R/W
0000BC <sub>H</sub>	I2C1 - Seven bit Slave address Register	ISBA1		R/W
0000BD <sub>H</sub>	I2C1 - Seven bit Address mask Register	ISMK1		R/W
0000BE <sub>H</sub>	I2C1 - Data Register	IDAR1		R/W
0000BF <sub>H</sub>	I2C1 - Clock Control Register	ICCR1		R/W
0000C0 <sub>H</sub>	USART0 - Serial Mode Register	SMR0		R/W
0000C1 <sub>H</sub>	USART0 - Serial Control Register	SCR0		R/W
0000C2 <sub>H</sub>	USART0 - TX Register	TDR0		W
0000C2 <sub>H</sub>	USART0 - RX Register	RDR0		R
0000C3 <sub>H</sub>	USART0 - Serial Status	SSR0		R/W
0000C4 <sub>H</sub>	USART0 - Control/Com. Register	ECCR0		R/W
0000C5 <sub>H</sub>	USART0 - Ext. Status Register	ESCR0		R/W
0000C6 <sub>H</sub>	USART0 - Baud Rate Generator Register Low	BGRL0	BGR0	R/W
0000C7 <sub>H</sub>	USART0 - Baud Rate Generator Register High	BGRH0		R/W
0000C8 <sub>H</sub>	USART0 - Extended Serial Interrupt Register	ESIR0		R/W
0000C9 <sub>H</sub>	Reserved			-
0000CA <sub>H</sub>	USART1 - Serial Mode Register	SMR1		R/W

## I/O map MB96(F)37x (8 of 34)

Address	Register	Abbreviation 8-bit access	Abbreviation 16-bit access	Access
0000CB <sub>H</sub>	USART1 - Serial Control Register	SCR1		R/W
0000CC <sub>H</sub>	USART1 - TX Register	TDR1		W
0000CC <sub>H</sub>	USART1 - RX Register	RDR1		R
0000CD <sub>H</sub>	USART1 - Serial Status	SSR1		R/W
0000CE <sub>H</sub>	USART1 - Control/Com. Register	ECCR1		R/W
0000CF <sub>H</sub>	USART1 - Ext. Status Register	ESCR1		R/W
0000D0 <sub>H</sub>	USART1 - Baud Rate Generator Register Low	BGRL1	BGR1	R/W
0000D1 <sub>H</sub>	USART1 - Baud Rate Generator Register High	BGRH1		R/W
0000D2 <sub>H</sub>	USART1 - Extended Serial Interrupt Register	ESIR1		R/W
0000D3 <sub>H</sub>	Reserved			-
0000D4 <sub>H</sub>	USART2 - Serial Mode Register	SMR2		R/W
0000D5 <sub>H</sub>	USART2 - Serial Control Register	SCR2		R/W
0000D6 <sub>H</sub>	USART2 - TX Register	TDR2		W
0000D6 <sub>H</sub>	USART2 - RX Register	RDR2		R
0000D7 <sub>H</sub>	USART2 - Serial Status	SSR2		R/W
0000D8 <sub>H</sub>	USART2 - Control/Com. Register	ECCR2		R/W
0000D9 <sub>H</sub>	USART2 - Ext. Status Register	ESCR2		R/W
0000DA <sub>H</sub>	USART2 - Baud Rate Generator Register Low	BGRL2	BGR2	R/W
0000DB <sub>H</sub>	USART2 - Baud Rate Generator Register High	BGRH2		R/W
0000DC <sub>H</sub>	USART2 - Extended Serial Interrupt Register	ESIR2		R/W
0000DD <sub>H</sub>	Reserved			-
0000DE <sub>H</sub>	USART3 - Serial Mode Register	SMR3		R/W
0000DF <sub>H</sub>	USART3 - Serial Control Register	SCR3		R/W
0000E0 <sub>H</sub>	USART3 - TX Register	TDR3		W
0000E0 <sub>H</sub>	USART3 - RX Register	RDR3		R
0000E1 <sub>H</sub>	USART3 - Serial Status	SSR3		R/W
0000E2 <sub>H</sub>	USART3 - Control/Com. Register	ECCR3		R/W
0000E3 <sub>H</sub>	USART3 - Ext. Status Register	ESCR3		R/W
0000E4 <sub>H</sub>	USART3 - Baud Rate Generator Register Low	BGRL3	BGR3	R/W
0000E5 <sub>H</sub>	USART3 - Baud Rate Generator Register High	BGRH3		R/W

# MB96370 Series

## I/O map MB96(F)37x (9 of 34)

Address	Register	Abbreviation 8-bit access	Abbreviation 16-bit access	Access
0000E6 <sub>H</sub>	USART3 - Extended Serial Interrupt Register	ESIR3		R/W
0000E7 <sub>H</sub> - 0000EF <sub>H</sub>	Reserved			-
0000F0 <sub>H</sub> - 0000FF <sub>H</sub>	External Bus area	EXTBUS0		R/W
000100 <sub>H</sub>	DMA0 - Buffer address pointer low byte	BAPL0		R/W
000101 <sub>H</sub>	DMA0 - Buffer address pointer middle byte	BAPM0		R/W
000102 <sub>H</sub>	DMA0 - Buffer address pointer high byte	BAPH0		R/W
000103 <sub>H</sub>	DMA0 - DMA control register	DMACS0		R/W
000104 <sub>H</sub>	DMA0 - I/O register address pointer low byte	IOAL0	IOA0	R/W
000105 <sub>H</sub>	DMA0 - I/O register address pointer high byte	IOAH0		R/W
000106 <sub>H</sub>	DMA0 - Data counter low byte	DCTL0	DCT0	R/W
000107 <sub>H</sub>	DMA0 - Data counter high byte	DCTH0		R/W
000108 <sub>H</sub>	DMA1 - Buffer address pointer low byte	BAPL1		R/W
000109 <sub>H</sub>	DMA1 - Buffer address pointer middle byte	BAPM1		R/W
00010A <sub>H</sub>	DMA1 - Buffer address pointer high byte	BAPH1		R/W
00010B <sub>H</sub>	DMA1 - DMA control register	DMACS1		R/W
00010C <sub>H</sub>	DMA1 - I/O register address pointer low byte	IOAL1	IOA1	R/W
00010D <sub>H</sub>	DMA1 - I/O register address pointer high byte	IOAH1		R/W
00010E <sub>H</sub>	DMA1 - Data counter low byte	DCTL1	DCT1	R/W
00010F <sub>H</sub>	DMA1 - Data counter high byte	DCTH1		R/W
000110 <sub>H</sub>	DMA2 - Buffer address pointer low byte	BAPL2		R/W
000111 <sub>H</sub>	DMA2 - Buffer address pointer middle byte	BAPM2		R/W
000112 <sub>H</sub>	DMA2 - Buffer address pointer high byte	BAPH2		R/W
000113 <sub>H</sub>	DMA2 - DMA control register	DMACS2		R/W
000114 <sub>H</sub>	DMA2 - I/O register address pointer low byte	IOAL2	IOA2	R/W
000115 <sub>H</sub>	DMA2 - I/O register address pointer high byte	IOAH2		R/W
000116 <sub>H</sub>	DMA2 - Data counter low byte	DCTL2	DCT2	R/W
000117 <sub>H</sub>	DMA2 - Data counter high byte	DCTH2		R/W
000118 <sub>H</sub>	DMA3 - Buffer address pointer low byte	BAPL3		R/W
000119 <sub>H</sub>	DMA3 - Buffer address pointer middle byte	BAPM3		R/W



## I/O map MB96(F)37x (10 of 34)

Address	Register	Abbreviation 8-bit access	Abbreviation 16-bit access	Access
00011A <sub>H</sub>	DMA3 - Buffer address pointer high byte	BAPH3		R/W
00011B <sub>H</sub>	DMA3 - DMA control register	DMACS3		R/W
00011C <sub>H</sub>	DMA3 - I/O register address pointer low byte	IOAL3	IOA3	R/W
00011D <sub>H</sub>	DMA3 - I/O register address pointer high byte	IOAH3		R/W
00011E <sub>H</sub>	DMA3 - Data counter low byte	DCTL3	DCT3	R/W
00011F <sub>H</sub>	DMA3 - Data counter high byte	DCTH3		R/W
000120 <sub>H</sub>	DMA4 - Buffer address pointer low byte	BAPL4		R/W
000121 <sub>H</sub>	DMA4 - Buffer address pointer middle byte	BAPM4		R/W
000122 <sub>H</sub>	DMA4 - Buffer address pointer high byte	BAPH4		R/W
000123 <sub>H</sub>	DMA4 - DMA control register	DMACS4		R/W
000124 <sub>H</sub>	DMA4 - I/O register address pointer low byte	IOAL4	IOA4	R/W
000125 <sub>H</sub>	DMA4 - I/O register address pointer high byte	IOAH4		R/W
000126 <sub>H</sub>	DMA4 - Data counter low byte	DCTL4	DCT4	R/W
000127 <sub>H</sub>	DMA4 - Data counter high byte	DCTH4		R/W
000128 <sub>H</sub>	DMA5 - Buffer address pointer low byte	BAPL5		R/W
000129 <sub>H</sub>	DMA5 - Buffer address pointer middle byte	BAPM5		R/W
00012A <sub>H</sub>	DMA5 - Buffer address pointer high byte	BAPH5		R/W
00012B <sub>H</sub>	DMA5 - DMA control register	DMACS5		R/W
00012C <sub>H</sub>	DMA5 - I/O register address pointer low byte	IOAL5	IOA5	R/W
00012D <sub>H</sub>	DMA5 - I/O register address pointer high byte	IOAH5		R/W
00012E <sub>H</sub>	DMA5 - Data counter low byte	DCTL5	DCT5	R/W
00012F <sub>H</sub>	DMA5 - Data counter high byte	DCTH5		R/W
000130 <sub>H</sub>	DMA6 - Buffer address pointer low byte	BAPL6		R/W
000131 <sub>H</sub>	DMA6 - Buffer address pointer middle byte	BAPM6		R/W
000132 <sub>H</sub>	DMA6 - Buffer address pointer high byte	BAPH6		R/W
000133 <sub>H</sub>	DMA6 - DMA control register	DMACS6		R/W
000134 <sub>H</sub>	DMA6 - I/O register address pointer low byte	IOAL6	IOA6	R/W
000135 <sub>H</sub>	DMA6 - I/O register address pointer high byte	IOAH6		R/W
000136 <sub>H</sub>	DMA6 - Data counter low byte	DCTL6	DCT6	R/W
000137 <sub>H</sub>	DMA6 - Data counter high byte	DCTH6		R/W

# MB96370 Series

## I/O map MB96(F)37x (11 of 34)

Address	Register	Abbreviation 8-bit access	Abbreviation 16-bit access	Access
000138 <sub>H</sub> - 00017F <sub>H</sub>	Reserved			-
000180 <sub>H</sub> - 00037F <sub>H</sub>	CPU - General Purpose registers (RAM access)	GPR_RAM		R/W
000380 <sub>H</sub>	DMA0 - Interrupt select	DISEL0		R/W
000381 <sub>H</sub>	DMA1 - Interrupt select	DISEL1		R/W
000382 <sub>H</sub>	DMA2 - Interrupt select	DISEL2		R/W
000383 <sub>H</sub>	DMA3 - Interrupt select	DISEL3		R/W
000384 <sub>H</sub>	DMA4 - Interrupt select	DISEL4		R/W
000385 <sub>H</sub>	DMA5 - Interrupt select	DISEL5		R/W
000386 <sub>H</sub>	DMA6 - Interrupt select	DISEL6		R/W
000387 <sub>H</sub> - 00038F <sub>H</sub>	Reserved			-
000390 <sub>H</sub>	DMA - Status register low byte	DSRL	DSR	R/W
000391 <sub>H</sub>	DMA - Status register high byte	DSRH		R/W
000392 <sub>H</sub>	DMA - Stop status register low byte	DSSRL	DSSR	R/W
000393 <sub>H</sub>	DMA - Stop status register high byte	DSSRH		R/W
000394 <sub>H</sub>	DMA - Enable register low byte	DERL	DER	R/W
000395 <sub>H</sub>	DMA - Enable register high byte	DERH		R/W
000396 <sub>H</sub> - 00039F <sub>H</sub>	Reserved			-
0003A0 <sub>H</sub>	Interrupt level register	ILR	ICR	R/W
0003A1 <sub>H</sub>	Interrupt index register	IDX		R/W
0003A2 <sub>H</sub>	Interrupt vector table base register Low	TBRL	TBR	R/W
0003A3 <sub>H</sub>	Interrupt vector table base register High	TBRH		R/W
0003A4 <sub>H</sub>	Delayed Interrupt register	DIRR		R/W
0003A5 <sub>H</sub>	Non Maskable Interrupt register	NMI		R/W
0003A6 <sub>H</sub> - 0003AB <sub>H</sub>	Reserved			-
0003AC <sub>H</sub>	EDSU communication interrupt selection Low	EDSU2L	EDSU2	R/W
0003AD <sub>H</sub>	EDSU communication interrupt selection High	EDSU2H		R/W
0003AE <sub>H</sub>	ROM mirror control register	ROMM		R/W

## I/O map MB96(F)37x (12 of 34)

Address	Register	Abbreviation 8-bit access	Abbreviation 16-bit access	Access
0003AF <sub>H</sub>	EDSU configuration register	EDSU		R/W
0003B0 <sub>H</sub>	Memory patch control/status register ch 0/1		PFCS0	R/W
0003B1 <sub>H</sub>	Memory patch control/status register ch 0/1			R/W
0003B2 <sub>H</sub>	Memory patch control/status register ch 2/3		PFCS1	R/W
0003B3 <sub>H</sub>	Memory patch control/status register ch 2/3			R/W
0003B4 <sub>H</sub>	Memory patch control/status register ch 4/5		PFCS2	R/W
0003B5 <sub>H</sub>	Memory patch control/status register ch 4/5			R/W
0003B6 <sub>H</sub>	Memory patch control/status register ch 6/7		PFCS3	R/W
0003B7 <sub>H</sub>	Memory patch control/status register ch 6/7			R/W
0003B8 <sub>H</sub>	Memory Patch function - Patch address 0 low	PFAL0		R/W
0003B9 <sub>H</sub>	Memory Patch function - Patch address 0 middle	PFAM0		R/W
0003BA <sub>H</sub>	Memory Patch function - Patch address 0 high	PFAH0		R/W
0003BB <sub>H</sub>	Memory Patch function - Patch address 1 low	PFAL1		R/W
0003BC <sub>H</sub>	Memory Patch function - Patch address 1 middle	PFAM1		R/W
0003BD <sub>H</sub>	Memory Patch function - Patch address 1 high	PFAH1		R/W
0003BE <sub>H</sub>	Memory Patch function - Patch address 2 low	PFAL2		R/W
0003BF <sub>H</sub>	Memory Patch function - Patch address 2 middle	PFAM2		R/W
0003C0 <sub>H</sub>	Memory Patch function - Patch address 2 high	PFAH2		R/W
0003C1 <sub>H</sub>	Memory Patch function - Patch address 3 low	PFAL3		R/W
0003C2 <sub>H</sub>	Memory Patch function - Patch address 3 middle	PFAM3		R/W
0003C3 <sub>H</sub>	Memory Patch function - Patch address 3 high	PFAH3		R/W
0003C4 <sub>H</sub>	Memory Patch function - Patch address 4 low	PFAL4		R/W
0003C5 <sub>H</sub>	Memory Patch function - Patch address 4 middle	PFAM4		R/W
0003C6 <sub>H</sub>	Memory Patch function - Patch address 4 high	PFAH4		R/W
0003C7 <sub>H</sub>	Memory Patch function - Patch address 5 low	PFAL5		R/W
0003C8 <sub>H</sub>	Memory Patch function - Patch address 5 middle	PFAM5		R/W
0003C9 <sub>H</sub>	Memory Patch function - Patch address 5 high	PFAH5		R/W
0003CA <sub>H</sub>	Memory Patch function - Patch address 6 low	PFAL6		R/W
0003CB <sub>H</sub>	Memory Patch function - Patch address 6 middle	PFAM6		R/W
0003CC <sub>H</sub>	Memory Patch function - Patch address 6 high	PFAH6		R/W

# MB96370 Series

## I/O map MB96(F)37x (13 of 34)

Address	Register	Abbreviation 8-bit access	Abbreviation 16-bit access	Access
0003CD <sub>H</sub>	Memory Patch function - Patch address 7 low	PFAL7		R/W
0003CE <sub>H</sub>	Memory Patch function - Patch address 7 middle	PFAM7		R/W
0003CF <sub>H</sub>	Memory Patch function - Patch address 7 high	PFAH7		R/W
0003D0 <sub>H</sub>	Memory Patch function - Patch data 0 Low	PFDL0	PFD0	R/W
0003D1 <sub>H</sub>	Memory Patch function - Patch data 0 High	PFDH0		R/W
0003D2 <sub>H</sub>	Memory Patch function - Patch data 1 Low	PFDL1	PFD1	R/W
0003D3 <sub>H</sub>	Memory Patch function - Patch data 1 High	PFDH1		R/W
0003D4 <sub>H</sub>	Memory Patch function - Patch data 2 Low	PFDL2	PFD2	R/W
0003D5 <sub>H</sub>	Memory Patch function - Patch data 2 High	PFDH2		R/W
0003D6 <sub>H</sub>	Memory Patch function - Patch data 3 Low	PFDL3	PFD3	R/W
0003D7 <sub>H</sub>	Memory Patch function - Patch data 3 High	PFDH3		R/W
0003D8 <sub>H</sub>	Memory Patch function - Patch data 4 Low	PFDL4	PFD4	R/W
0003D9 <sub>H</sub>	Memory Patch function - Patch data 4 High	PFDH4		R/W
0003DA <sub>H</sub>	Memory Patch function - Patch data 5 Low	PFDL5	PFD5	R/W
0003DB <sub>H</sub>	Memory Patch function - Patch data 5 High	PFDH5		R/W
0003DC <sub>H</sub>	Memory Patch function - Patch data 6 Low	PFDL6	PFD6	R/W
0003DD <sub>H</sub>	Memory Patch function - Patch data 6 High	PFDH6		R/W
0003DE <sub>H</sub>	Memory Patch function - Patch data 7 Low	PFDL7	PFD7	R/W
0003DF <sub>H</sub>	Memory Patch function - Patch data 7 High	PFDH7		R/W
0003E0 <sub>H</sub> - 0003F0 <sub>H</sub>	Reserved			-
0003F1 <sub>H</sub>	Memory Control Status Register A	MCSRA		R/W
0003F2 <sub>H</sub>	Memory Timing Configuration Register A Low	MTCRAL	MTCRA	R/W
0003F3 <sub>H</sub>	Memory Timing Configuration Register A High	MTCRAH		R/W
0003F4 <sub>H</sub>	Reserved			-
0003F5 <sub>H</sub>	Memory Control Status Register B	MCSR B		R/W
0003F6 <sub>H</sub>	Memory Timing Configuration Register B Low	MTCRBL	MTCRB	R/W
0003F7 <sub>H</sub>	Memory Timing Configuration Register B High	MTCRBH		R/W
0003F8 <sub>H</sub>	Flash Memory Write Control register 0	FMWC0		R/W
0003F9 <sub>H</sub>	Flash Memory Write Control register 1	FMWC1		R/W

## I/O map MB96(F)37x (14 of 34)

Address	Register	Abbreviation 8-bit access	Abbreviation 16-bit access	Access
0003FA <sub>H</sub>	Flash Memory Write Control register 2	FMWC2		R/W
0003FB <sub>H</sub>	Flash Memory Write Control register 3	FMWC3		R/W
0003FC <sub>H</sub>	Flash Memory Write Control register 4	FMWC4		R/W
0003FD <sub>H</sub>	Flash Memory Write Control register 5	FMWC5		R/W
0003FE <sub>H</sub> - 0003FF <sub>H</sub>	Reserved			-
000400 <sub>H</sub>	Standby Mode control register	SMCR		R/W
000401 <sub>H</sub>	Clock select register	CKSR		R/W
000402 <sub>H</sub>	Clock Stabilisation select register	CKSSR		R/W
000403 <sub>H</sub>	Clock monitor register	CKMR		R
000404 <sub>H</sub>	Clock Frequency control register Low	CKFCRL	CKFCR	R/W
000405 <sub>H</sub>	Clock Frequency control register High	CKFCRH		R/W
000406 <sub>H</sub>	PLL Control register Low	PLLCRL	PLLCR	R/W
000407 <sub>H</sub>	PLL Control register High	PLLCRH		R/W
000408 <sub>H</sub>	RC clock timer control register	RCTCR		R/W
000409 <sub>H</sub>	Main clock timer control register	MCTCR		R/W
00040A <sub>H</sub>	Sub clock timer control register	SCTCR		R/W
00040B <sub>H</sub>	Reset cause and clock status register with clear function	RCCSRC		R
00040C <sub>H</sub>	Reset configuration register	RCR		R/W
00040D <sub>H</sub>	Reset cause and clock status register	RCCSR		R
00040E <sub>H</sub>	Watch dog timer configuration register	WDTC		R/W
00040F <sub>H</sub>	Watch dog timer clear pattern register	WDTCP		W
000410 <sub>H</sub> - 000414 <sub>H</sub>	Reserved			-
000415 <sub>H</sub>	Clock output activation register	COAR		R/W
000416 <sub>H</sub>	Clock output configuration register 0	COCR0		R/W
000417 <sub>H</sub>	Clock output configuration register 1	COCR1		R/W
000418 <sub>H</sub>	Clock Modulator control register	CMCR		R/W
000419 <sub>H</sub>	Reserved			-
00041A <sub>H</sub>	Clock Modulator Parameter register Low	CMPRL	CMPR	R/W

# MB96370 Series

## I/O map MB96(F)37x (15 of 34)

Address	Register	Abbreviation 8-bit access	Abbreviation 16-bit access	Access
00041B <sub>H</sub>	Clock Modulator Parameter register High	CMPRH		R/W
00041C <sub>H</sub> - 00042B <sub>H</sub>	Reserved			-
00042C <sub>H</sub>	Voltage Regulator Control register	VRRCR		R/W
00042D <sub>H</sub>	Clock Input and LVD Control Register	CILCR		R/W
00042E <sub>H</sub> - 00042F <sub>H</sub>	Reserved			-
000430 <sub>H</sub>	I/O Port P00 - Data Direction Register	DDR00		R/W
000431 <sub>H</sub>	I/O Port P01 - Data Direction Register	DDR01		R/W
000432 <sub>H</sub>	I/O Port P02 - Data Direction Register	DDR02		R/W
000433 <sub>H</sub>	I/O Port P03 - Data Direction Register	DDR03		R/W
000434 <sub>H</sub>	I/O Port P04 - Data Direction Register	DDR04		R/W
000435 <sub>H</sub>	I/O Port P05 - Data Direction Register	DDR05		R/W
000436 <sub>H</sub>	I/O Port P06 - Data Direction Register	DDR06		R/W
000437 <sub>H</sub>	I/O Port P07 - Data Direction Register	DDR07		R/W
000438 <sub>H</sub>	I/O Port P08 - Data Direction Register	DDR08		R/W
000439 <sub>H</sub>	I/O Port P09 - Data Direction Register	DDR09		R/W
00043A <sub>H</sub>	I/O Port P10 - Data Direction Register	DDR10		R/W
00043B <sub>H</sub>	I/O Port P11 - Data Direction Register	DDR11		R/W
00043C <sub>H</sub>	I/O Port P12 - Data Direction Register	DDR12		R/W
00043D <sub>H</sub>	I/O Port P13 - Data Direction Register	DDR13		R/W
00043E <sub>H</sub> - 00043F <sub>H</sub>	Reserved			-
000440 <sub>H</sub>	I/O Port P16 - Data Direction Register	DDR16		R/W
000441 <sub>H</sub> - 000443 <sub>H</sub>	Reserved			-
000444 <sub>H</sub>	I/O Port P00 - Port Input Enable Register	PIER00		R/W
000445 <sub>H</sub>	I/O Port P01 - Port Input Enable Register	PIER01		R/W
000446 <sub>H</sub>	I/O Port P02 - Port Input Enable Register	PIER02		R/W
000447 <sub>H</sub>	I/O Port P03 - Port Input Enable Register	PIER03		R/W
000448 <sub>H</sub>	I/O Port P04 - Port Input Enable Register	PIER04		R/W

## I/O map MB96(F)37x (16 of 34)

Address	Register	Abbreviation 8-bit access	Abbreviation 16-bit access	Access
000449 <sub>H</sub>	I/O Port P05 - Port Input Enable Register	PIER05		R/W
00044A <sub>H</sub>	I/O Port P06 - Port Input Enable Register	PIER06		R/W
00044B <sub>H</sub>	I/O Port P07 - Port Input Enable Register	PIER07		R/W
00044C <sub>H</sub>	I/O Port P08 - Port Input Enable Register	PIER08		R/W
00044D <sub>H</sub>	I/O Port P09 - Port Input Enable Register	PIER09		R/W
00044E <sub>H</sub>	I/O Port P10 - Port Input Enable Register	PIER10		R/W
00044F <sub>H</sub>	I/O Port P11 - Port Input Enable Register	PIER11		R/W
000450 <sub>H</sub>	I/O Port P12 - Port Input Enable Register	PIER12		R/W
000451 <sub>H</sub>	I/O Port P13 - Port Input Enable Register	PIER13		R/W
000452 <sub>H</sub> - 000453 <sub>H</sub>	Reserved			-
000454 <sub>H</sub>	I/O Port P16 - Port Input Enable Register	PIER16		R/W
000455 <sub>H</sub> - 000457 <sub>H</sub>	Reserved			-
000458 <sub>H</sub>	I/O Port P00 - Port Input Level Register	PILR00		R/W
000459 <sub>H</sub>	I/O Port P01 - Port Input Level Register	PILR01		R/W
00045A <sub>H</sub>	I/O Port P02 - Port Input Level Register	PILR02		R/W
00045B <sub>H</sub>	I/O Port P03 - Port Input Level Register	PILR03		R/W
00045C <sub>H</sub>	I/O Port P04 - Port Input Level Register	PILR04		R/W
00045D <sub>H</sub>	I/O Port P05 - Port Input Level Register	PILR05		R/W
00045E <sub>H</sub>	I/O Port P06 - Port Input Level Register	PILR06		R/W
00045F <sub>H</sub>	I/O Port P07 - Port Input Level Register	PILR07		R/W
000460 <sub>H</sub>	I/O Port P08 - Port Input Level Register	PILR08		R/W
000461 <sub>H</sub>	I/O Port P09 - Port Input Level Register	PILR09		R/W
000462 <sub>H</sub>	I/O Port P10 - Port Input Level Register	PILR10		R/W
000463 <sub>H</sub>	I/O Port P11 - Port Input Level Register	PILR11		R/W
000464 <sub>H</sub>	I/O Port P12 - Port Input Level Register	PILR12		R/W
000465 <sub>H</sub>	I/O Port P13 - Port Input Level Register	PILR13		R/W
000466 <sub>H</sub> - 000467 <sub>H</sub>	Reserved			-
000468 <sub>H</sub>	I/O Port P16 - Port Input Level Register	PILR16		R/W

# MB96370 Series

## I/O map MB96(F)37x (17 of 34)

Address	Register	Abbreviation 8-bit access	Abbreviation 16-bit access	Access
000469 <sub>H</sub> - 00046B <sub>H</sub>	Reserved			-
00046C <sub>H</sub>	I/O Port P00 - Extended Port Input Level Register	EPILR00		R/W
00046D <sub>H</sub>	I/O Port P01 - Extended Port Input Level Register	EPILR01		R/W
00046E <sub>H</sub>	I/O Port P02 - Extended Port Input Level Register	EPILR02		R/W
00046F <sub>H</sub>	I/O Port P03 - Extended Port Input Level Register	EPILR03		R/W
000470 <sub>H</sub>	I/O Port P04 - Extended Port Input Level Register	EPILR04		R/W
000471 <sub>H</sub>	I/O Port P05 - Extended Port Input Level Register	EPILR05		R/W
000472 <sub>H</sub>	I/O Port P06 - Extended Port Input Level Register	EPILR06		R/W
000473 <sub>H</sub>	I/O Port P07 - Extended Port Input Level Register	EPILR07		R/W
000474 <sub>H</sub>	I/O Port P08 - Extended Port Input Level Register	EPILR08		R/W
000475 <sub>H</sub>	I/O Port P09 - Extended Port Input Level Register	EPILR09		R/W
000476 <sub>H</sub>	I/O Port P10 - Extended Port Input Level Register	EPILR10		R/W
000477 <sub>H</sub>	I/O Port P11 - Extended Port Input Level Register	EPILR11		R/W
000478 <sub>H</sub>	I/O Port P12 - Extended Port Input Level Register	EPILR12		R/W
000479 <sub>H</sub>	I/O Port P13 - Extended Port Input Level Register	EPILR13		R/W
00047A <sub>H</sub> - 00047B <sub>H</sub>	Reserved			-
00047C <sub>H</sub>	I/O Port P16 - Extended Port Input Level Register	EPILR16		R/W
00047D <sub>H</sub> - 00047F <sub>H</sub>	Reserved			-
000480 <sub>H</sub>	I/O Port P00 - Port Output Drive Register	PODR00		R/W
000481 <sub>H</sub>	I/O Port P01 - Port Output Drive Register	PODR01		R/W
000482 <sub>H</sub>	I/O Port P02 - Port Output Drive Register	PODR02		R/W
000483 <sub>H</sub>	I/O Port P03 - Port Output Drive Register	PODR03		R/W
000484 <sub>H</sub>	I/O Port P04 - Port Output Drive Register	PODR04		R/W
000485 <sub>H</sub>	I/O Port P05 - Port Output Drive Register	PODR05		R/W
000486 <sub>H</sub>	I/O Port P06 - Port Output Drive Register	PODR06		R/W
000487 <sub>H</sub>	I/O Port P07 - Port Output Drive Register	PODR07		R/W
000488 <sub>H</sub>	I/O Port P08 - Port Output Drive Register	PODR08		R/W
000489 <sub>H</sub>	I/O Port P09 - Port Output Drive Register	PODR09		R/W



## I/O map MB96(F)37x (18 of 34)

Address	Register	Abbreviation 8-bit access	Abbreviation 16-bit access	Access
00048A <sub>H</sub>	I/O Port P10 - Port Output Drive Register	PODR10		R/W
00048B <sub>H</sub>	I/O Port P11 - Port Output Drive Register	PODR11		R/W
00048C <sub>H</sub>	I/O Port P12 - Port Output Drive Register	PODR12		R/W
00048D <sub>H</sub>	I/O Port P13 - Port Output Drive Register	PODR13		R/W
00048E <sub>H</sub> - 00048F <sub>H</sub>	Reserved			-
000490 <sub>H</sub>	I/O Port P16 - Port Output Drive Register	PODR16		R/W
000491 <sub>H</sub> - 00049B <sub>H</sub>	Reserved			-
00049C <sub>H</sub>	I/O Port P08 - Port High Drive Register	PHDR08		R/W
00049D <sub>H</sub>	I/O Port P09 - Port High Drive Register	PHDR09		R/W
00049E <sub>H</sub>	I/O Port P10 - Port High Drive Register	PHDR10		R/W
00049F <sub>H</sub> - 0004A7 <sub>H</sub>	Reserved			-
0004A8 <sub>H</sub>	I/O Port P00 - Pull-Up resistor Control Register	PUCR00		R/W
0004A9 <sub>H</sub>	I/O Port P01 - Pull-Up resistor Control Register	PUCR01		R/W
0004AA <sub>H</sub>	I/O Port P02 - Pull-Up resistor Control Register	PUCR02		R/W
0004AB <sub>H</sub>	I/O Port P03 - Pull-Up resistor Control Register	PUCR03		R/W
0004AC <sub>H</sub>	I/O Port P04 - Pull-Up resistor Control Register	PUCR04		R/W
0004AD <sub>H</sub>	I/O Port P05 - Pull-Up resistor Control Register	PUCR05		R/W
0004AE <sub>H</sub>	I/O Port P06 - Pull-Up resistor Control Register	PUCR06		R/W
0004AF <sub>H</sub>	I/O Port P07 - Pull-Up resistor Control Register	PUCR07		R/W
0004B0 <sub>H</sub>	I/O Port P08 - Pull-Up resistor Control Register	PUCR08		R/W
0004B1 <sub>H</sub>	I/O Port P09 - Pull-Up resistor Control Register	PUCR09		R/W
0004B2 <sub>H</sub>	I/O Port P10 - Pull-Up resistor Control Register	PUCR10		R/W
0004B3 <sub>H</sub>	I/O Port P11 - Pull-Up resistor Control Register	PUCR11		R/W
0004B4 <sub>H</sub>	I/O Port P12 - Pull-Up resistor Control Register	PUCR12		R/W
0004B5 <sub>H</sub>	I/O Port P13 - Pull-Up resistor Control Register	PUCR13		R/W
0004B6 <sub>H</sub> - 0004B7 <sub>H</sub>	Reserved			-
0004B8 <sub>H</sub>	I/O Port P16 - Pull-Up resistor Control Register	PUCR16		R/W

# MB96370 Series

## I/O map MB96(F)37x (19 of 34)

Address	Register	Abbreviation 8-bit access	Abbreviation 16-bit access	Access
0004B9 <sub>H</sub> - 0004BB <sub>H</sub>	Reserved			-
0004BC <sub>H</sub>	I/O Port P00 - External Pin State Register	EPSR00		R
0004BD <sub>H</sub>	I/O Port P01 - External Pin State Register	EPSR01		R
0004BE <sub>H</sub>	I/O Port P02 - External Pin State Register	EPSR02		R
0004BF <sub>H</sub>	I/O Port P03 - External Pin State Register	EPSR03		R
0004C0 <sub>H</sub>	I/O Port P04 - External Pin State Register	EPSR04		R
0004C1 <sub>H</sub>	I/O Port P05 - External Pin State Register	EPSR05		R
0004C2 <sub>H</sub>	I/O Port P06 - External Pin State Register	EPSR06		R
0004C3 <sub>H</sub>	I/O Port P07 - External Pin State Register	EPSR07		R
0004C4 <sub>H</sub>	I/O Port P08 - External Pin State Register	EPSR08		R
0004C5 <sub>H</sub>	I/O Port P09 - External Pin State Register	EPSR09		R
0004C6 <sub>H</sub>	I/O Port P10 - External Pin State Register	EPSR10		R
0004C7 <sub>H</sub>	I/O Port P11 - External Pin State Register	EPSR11		R
0004C8 <sub>H</sub>	I/O Port P12 - External Pin State Register	EPSR12		R
0004C9 <sub>H</sub>	I/O Port P13 - External Pin State Register	EPSR13		R
0004CA <sub>H</sub> - 0004CB <sub>H</sub>	Reserved			-
0004CC <sub>H</sub>	I/O Port P16 - External Pin State Register	EPSR16		R
0004CD <sub>H</sub> - 0004CF <sub>H</sub>	Reserved			-
0004D0 <sub>H</sub>	ADC analog input enable register 0	ADER0		R/W
0004D1 <sub>H</sub>	ADC analog input enable register 1	ADER1		R/W
0004D2 <sub>H</sub>	ADC analog input enable register 2	ADER2		R/W
0004D3 <sub>H</sub>	ADC analog input enable register 3	ADER3		R/W
0004D4 <sub>H</sub>	ADC analog input enable register 4	ADER4		R/W
0004D5 <sub>H</sub>	Reserved			-
0004D6 <sub>H</sub>	Peripheral Resource Relocation Register 0	PRRR0		R/W
0004D7 <sub>H</sub>	Peripheral Resource Relocation Register 1	PRRR1		R/W
0004D8 <sub>H</sub>	Peripheral Resource Relocation Register 2	PRRR2		R/W
0004D9 <sub>H</sub>	Peripheral Resource Relocation Register 3	PRRR3		R/W

## I/O map MB96(F)37x (20 of 34)

Address	Register	Abbreviation 8-bit access	Abbreviation 16-bit access	Access
0004DA <sub>H</sub>	Peripheral Resource Relocation Register 4	PRRR4		R/W
0004DB <sub>H</sub>	Peripheral Resource Relocation Register 5	PRRR5		R/W
0004DC <sub>H</sub>	Peripheral Resource Relocation Register 6	PRRR6		R/W
0004DD <sub>H</sub>	Peripheral Resource Relocation Register 7	PRRR7		R/W
0004DE <sub>H</sub>	Peripheral Resource Relocation Register 8	PRRR8		R/W
0004DF <sub>H</sub>	Peripheral Resource Relocation Register 9	PRRR9		R/W
0004E0 <sub>H</sub>	RTC - Sub Second Register L	WTBRL0	WTBR0	R/W
0004E1 <sub>H</sub>	RTC - Sub Second Register M	WTBRH0		R/W
0004E2 <sub>H</sub>	RTC - Sub-Second Register H	WTBR1		R/W
0004E3 <sub>H</sub>	RTC - Second Register	WTSR		R/W
0004E4 <sub>H</sub>	RTC - Minutes	WTMR		R/W
0004E5 <sub>H</sub>	RTC - Hour	WTHR		R/W
0004E6 <sub>H</sub>	RTC - Timer Control Extended Register	WCER		R/W
0004E7 <sub>H</sub>	RTC - Clock select register	WTCKSR		R/W
0004E8 <sub>H</sub>	RTC - Timer Control Register Low	WTCRL	WTCR	R/W
0004E9 <sub>H</sub>	RTC - Timer Control Register High	WTCRH		R/W
0004EA <sub>H</sub>	CAL - Calibration unit Control register	CUCR		R/W
0004EB <sub>H</sub>	Reserved			-
0004EC <sub>H</sub>	CAL - Duration Timer Data Register Low	CUTDL	CUTD	R/W
0004ED <sub>H</sub>	CAL - Duration Timer Data Register High	CUTDH		R/W
0004EE <sub>H</sub>	CAL - Calibration Timer Register 2 Low	CUTR2L	CUTR2	R
0004EF <sub>H</sub>	CAL - Calibration Timer Register 2 High	CUTR2H		R
0004F0 <sub>H</sub>	CAL - Calibration Timer Register 1 Low	CUTR1L	CUTR1	R
0004F1 <sub>H</sub>	CAL - Calibration Timer Register 1 High	CUTR1H		R
0004F2 <sub>H</sub> - 0004F9 <sub>H</sub>	Reserved			-
0004FA <sub>H</sub>	RLT - Timer input select (for Cascading)	TMISR		R/W
0004FB <sub>H</sub> - 00051F <sub>H</sub>	Reserved			-
000520 <sub>H</sub>	USART4 - Serial Mode Register	SMR4		R/W
000521 <sub>H</sub>	USART4 - Serial Control Register	SCR4		R/W

# MB96370 Series

## I/O map MB96(F)37x (21 of 34)

Address	Register	Abbreviation 8-bit access	Abbreviation 16-bit access	Access
000522 <sub>H</sub>	USART4 - TX Register	TDR4		W
000522 <sub>H</sub>	USART4 - RX Register	RDR4		R
000523 <sub>H</sub>	USART4 - Serial Status	SSR4		R/W
000524 <sub>H</sub>	USART4 - Control/Com. Register (internal)	ECCR4		R/W
000525 <sub>H</sub>	USART4 - Ext. Status Register	ESCR4		R/W
000526 <sub>H</sub>	USART4 - Baud Rate Generator Register Low	BGRL4	BGR4	R/W
000527 <sub>H</sub>	USART4 - Baud Rate Generator Register High	BGRH4		R/W
000528 <sub>H</sub>	USART4 - Extended Serial Interrupt Register	ESIR4		R/W
000529 <sub>H</sub>	Reserved			-
00052A <sub>H</sub>	USART5 - Serial Mode Register	SMR5		R/W
00052B <sub>H</sub>	USART5 - Serial Control Register	SCR5		R/W
00052C <sub>H</sub>	USART5 - RX Register	TDR5		W
00052C <sub>H</sub>	USART5 - TX Register	RDR5		R
00052D <sub>H</sub>	USART5 - Serial Status	SSR5		R/W
00052E <sub>H</sub>	USART5 - Control/Com. Register	ECCR5		R/W
00052F <sub>H</sub>	USART5 - Ext. Status Register	ESCR5		R/W
000530 <sub>H</sub>	USART5 - Baud Rate Generator Register Low	BGRL5	BGR5	R/W
000531 <sub>H</sub>	USART5 - Baud Rate Generator Register High	BGRH5		R/W
000532 <sub>H</sub>	USART5 - Extended Serial Interrupt Register	ESIR5		R/W
000533 <sub>H</sub> - 00055F <sub>H</sub>	Reserved			-
000560 <sub>H</sub>	ALARM0 - Control Status Register	ACSR0		R/W
000561 <sub>H</sub>	ALARM0 - Extended Control Status Register	AECSR0		R/W
000562 <sub>H</sub>	ALARM1 - Control Status Register	ACSR1		R/W
000563 <sub>H</sub>	ALARM1 - Extended Control Status Register	AECSR1		R/W
000564 <sub>H</sub>	PPG6 - Timer register		PTMR6	R
000565 <sub>H</sub>	PPG6 - Timer register			R
000566 <sub>H</sub>	PPG6 - Period setting register		PCSR6	W
000567 <sub>H</sub>	PPG6 - Period setting register			W
000568 <sub>H</sub>	PPG6 - Duty cycle register		PDUT6	W

## I/O map MB96(F)37x (22 of 34)

Address	Register	Abbreviation 8-bit access	Abbreviation 16-bit access	Access
000569 <sub>H</sub>	PPG6 - Duty cycle register			W
00056A <sub>H</sub>	PPG6 - Control status register Low	PCNL6	PCN6	R/W
00056B <sub>H</sub>	PPG6 - Control status register High	PCNH6		R/W
00056C <sub>H</sub>	PPG7 - Timer register		PTMR7	R
00056D <sub>H</sub>	PPG7 - Timer register			R
00056E <sub>H</sub>	PPG7 - Period setting register		PCSR7	W
00056F <sub>H</sub>	PPG7 - Period setting register			W
000570 <sub>H</sub>	PPG7 - Duty cycle register		PDUT7	W
000571 <sub>H</sub>	PPG7 - Duty cycle register			W
000572 <sub>H</sub>	PPG7 - Control status register Low	PCNL7	PCN7	R/W
000573 <sub>H</sub>	PPG7 - Control status register High	PCNH7		R/W
000574 <sub>H</sub>	PPG11-PPG8 - General Control register 1 Low	GCN1L2	GCN12	R/W
000575 <sub>H</sub>	PPG11-PPG8 - General Control register 1 High	GCN1H2		R/W
000576 <sub>H</sub>	PPG11-PPG8 - General Control register 2 Low	GCN2L2	GCN22	R/W
000577 <sub>H</sub>	PPG11-PPG8 - General Control register 2 High	GCN2H2		R/W
000578 <sub>H</sub>	PPG8 - Timer register		PTMR8	R
000579 <sub>H</sub>	PPG8 - Timer register			R
00057A <sub>H</sub>	PPG8 - Period setting register		PCSR8	W
00057B <sub>H</sub>	PPG8 - Period setting register			W
00057C <sub>H</sub>	PPG8 - Duty cycle register		PDUT8	W
00057D <sub>H</sub>	PPG8 - Duty cycle register			W
00057E <sub>H</sub>	PPG8 - Control status register Low	PCNL8	PCN8	R/W
00057F <sub>H</sub>	PPG8 - Control status register High	PCNH8		R/W
000580 <sub>H</sub>	PPG9 - Timer register		PTMR9	R
000581 <sub>H</sub>	PPG9 - Timer register			R
000582 <sub>H</sub>	PPG9 - Period setting register		PCSR9	W
000583 <sub>H</sub>	PPG9 - Period setting register			W
000584 <sub>H</sub>	PPG9 - Duty cycle register		PDUT9	W
000585 <sub>H</sub>	PPG9 - Duty cycle register			W
000586 <sub>H</sub>	PPG9 - Control status register Low	PCNL9	PCN9	R/W

# MB96370 Series

## I/O map MB96(F)37x (23 of 34)

Address	Register	Abbreviation 8-bit access	Abbreviation 16-bit access	Access
000587 <sub>H</sub>	PPG9 - Control status register High	PCNH9		R/W
000588 <sub>H</sub>	PPG10 - Timer register		PTMR10	R
000589 <sub>H</sub>	PPG10 - Timer register			R
00058A <sub>H</sub>	PPG10 - Period setting register		PCSR10	W
00058B <sub>H</sub>	PPG10 - Period setting register			W
00058C <sub>H</sub>	PPG10 - Duty cycle register		PDUT10	W
00058D <sub>H</sub>	PPG10 - Duty cycle register			W
00058E <sub>H</sub>	PPG10 - Control status register Low	PCNL10	PCN10	R/W
00058F <sub>H</sub>	PPG10 - Control status register High	PCNH10		R/W
000590 <sub>H</sub>	PPG11 - Timer register		PTMR11	R
000591 <sub>H</sub>	PPG11 - Timer register			R
000592 <sub>H</sub>	PPG11 - Period setting register		PCSR11	W
000593 <sub>H</sub>	PPG11 - Period setting register			W
000594 <sub>H</sub>	PPG11 - Duty cycle register		PDUT11	W
000595 <sub>H</sub>	PPG11 - Duty cycle register			W
000596 <sub>H</sub>	PPG11 - Control status register Low	PCNL11	PCN11	R/W
000597 <sub>H</sub>	PPG11 - Control status register High	PCNH11		R/W
000598 <sub>H</sub> - 0005DF <sub>H</sub>	Reserved			-
0005E0 <sub>H</sub>	SMC0 - PWM control register	PWC0		R/W
0005E1 <sub>H</sub>	SMC0 - Extended control register (Output enable)	PWEC0		R/W
0005E2 <sub>H</sub>	SMC0 - PWM compare register PWM 1		PWC10	R/W
0005E3 <sub>H</sub>	SMC0 - PWM compare register PWM 1			R/W
0005E4 <sub>H</sub>	SMC0 - PWM compare register PWM 2		PWC20	R/W
0005E5 <sub>H</sub>	SMC0 - PWM compare register PWM 2			R/W
0005E6 <sub>H</sub>	SMC0 - PWM Select register	PWS10		R/W
0005E7 <sub>H</sub>	SMC0 - PWM Select register	PWS20		R/W
0005E8 <sub>H</sub> - 0005E9 <sub>H</sub>	Reserved			-
0005EA <sub>H</sub>	SMC1 - PWM control register	PWC1		R/W

## I/O map MB96(F)37x (24 of 34)

Address	Register	Abbreviation 8-bit access	Abbreviation 16-bit access	Access
0005EB <sub>H</sub>	SMC1 - Extended control register (Output enable)	PWEC1		R/W
0005EC <sub>H</sub>	SMC1 - PWM compare register PWM 1		PWC11	R/W
0005ED <sub>H</sub>	SMC1 - PWM compare register PWM 1			R/W
0005EE <sub>H</sub>	SMC1 - PWM compare register PWM 2		PWC21	R/W
0005EF <sub>H</sub>	SMC1 - PWM compare register PWM 2			R/W
0005F0 <sub>H</sub>	SMC1 - PWM Select register	PWS11		R/W
0005F1 <sub>H</sub>	SMC1 - PWM Select register	PWS21		R/W
0005F2 <sub>H</sub> - 0005F3 <sub>H</sub>	Reserved			-
0005F4 <sub>H</sub>	SMC2 - PWM control register	PWC2		R/W
0005F5 <sub>H</sub>	SMC2 - Extended control register (Output enable)	PWEC2		R/W
0005F6 <sub>H</sub>	SMC2 - PWM compare register PWM 1		PWC12	R/W
0005F7 <sub>H</sub>	SMC2 - PWM compare register PWM 1			R/W
0005F8 <sub>H</sub>	SMC2 - PWM compare register PWM 2		PWC22	R/W
0005F9 <sub>H</sub>	SMC2 - PWM compare register PWM 2			R/W
0005FA <sub>H</sub>	SMC2 - PWM Select register	PWS12		R/W
0005FB <sub>H</sub>	SMC2 - PWM Select register	PWS22		R/W
0005FC <sub>H</sub> - 0005FD <sub>H</sub>	Reserved			-
0005FE <sub>H</sub>	SMC3 - PWM control register	PWC3		R/W
0005FF <sub>H</sub>	SMC3 - Extended control register (Output enable)	PWEC3		R/W
000600 <sub>H</sub>	SMC3 - PWM compare register PWM 1		PWC13	R/W
000601 <sub>H</sub>	SMC3 - PWM compare register PWM 1			R/W
000602 <sub>H</sub>	SMC3 - PWM compare register PWM 2		PWC23	R/W
000603 <sub>H</sub>	SMC3 - PWM compare register PWM 2			R/W
000604 <sub>H</sub>	SMC3 - PWM Select register	PWS13		R/W
000605 <sub>H</sub>	SMC3 - PWM Select register	PWS23		R/W
000606 <sub>H</sub> - 000607 <sub>H</sub>	Reserved			-

# MB96370 Series

## I/O map MB96(F)37x (25 of 34)

Address	Register	Abbreviation 8-bit access	Abbreviation 16-bit access	Access
000608 <sub>H</sub>	SMC4 - PWM control register	PWC4		R/W
000609 <sub>H</sub>	SMC4 - Extended control register (Output enable)	PWEC4		R/W
00060A <sub>H</sub>	SMC4 - PWM compare register PWM 1		PWC14	R/W
00060B <sub>H</sub>	SMC4 - PWM compare register PWM 1			R/W
00060C <sub>H</sub>	SMC4 - PWM compare register PWM 2		PWC24	R/W
00060D <sub>H</sub>	SMC4 - PWM compare register PWM 2			R/W
00060E <sub>H</sub>	SMC4 - PWM Select register	PWS14		R/W
00060F <sub>H</sub>	SMC4 - PWM Select register	PWS24		R/W
000610 <sub>H</sub> - 000611 <sub>H</sub>	Reserved			-
000612 <sub>H</sub>	SMC5 - PWM control register	PWC5		R/W
000613 <sub>H</sub>	SMC5 - Extended control register (Output enable)	PWEC5		R/W
000614 <sub>H</sub>	SMC5 - PWM compare register PWM 1		PWC15	R/W
000615 <sub>H</sub>	SMC5 - PWM compare register PWM 1			R/W
000616 <sub>H</sub>	SMC5 - PWM compare register PWM 2		PWC25	R/W
000617 <sub>H</sub>	SMC5 - PWM compare register PWM 2			R/W
000618 <sub>H</sub>	SMC5 - PWM Select register	PWS15		R/W
000619 <sub>H</sub>	SMC5 - PWM Select register	PWS25		R/W
00061A <sub>H</sub> - 00061B <sub>H</sub>	Reserved			-
00061C <sub>H</sub>	LCD - Output Enable Register 0 (Seg 7-0)	LCDER0		R/W
00061D <sub>H</sub>	LCD - Output Enable Register 1 (Seg 15-8)	LCDER1		R/W
00061E <sub>H</sub>	LCD - Output Enable Register 2 (Seg 23-16)	LCDER2		R/W
00061F <sub>H</sub>	LCD - Output Enable Register 3 (Seg 31-24)	LCDER3		R/W
000620 <sub>H</sub>	LCD - Output Enable Register 4 (Seg 39-32)	LCDER4		R/W
000621 <sub>H</sub>	LCD - Output Enable Register 5 (Seg 47-40)	LCDER5		R/W
000622 <sub>H</sub>	LCD - Output Enable Register 6 (Seg 55-48)	LCDER6		R/W
000623 <sub>H</sub>	LCD - Output Enable Register 7 (Seg 63-56)	LCDER7		R/W
000624 <sub>H</sub>	LCD - Output Enable Register 8 (Seg 71-64)	LCDER8		R/W



## I/O map MB96(F)37x (26 of 34)

Address	Register	Abbreviation 8-bit access	Abbreviation 16-bit access	Access
000625H	Reserved			-
000626H	LCD - Output Enable Register V (Vx)	LCDVER		R/W
000627H	LCD - Extended Control Register	LECR		R/W
000628H	LCD - Common pin switching register	LCDCMR		R/W
000629H	LCD - Control Register	LCR		R/W
00062AH	LCD - Data register for Segment 1-0	VRAM0		R/W
00062BH	LCD - Data register for Segment 3-2	VRAM1		R/W
00062CH	LCD - Data register for Segment 5-4	VRAM2		R/W
00062DH	LCD - Data register for Segment 7-6	VRAM3		R/W
00062EH	LCD - Data register for Segment 9-8	VRAM4		R/W
00062FH	LCD - Data register for Segment 11-10	VRAM5		R/W
000630H	LCD - Data register for Segment 13-12	VRAM6		R/W
000631H	LCD - Data register for Segment 15-14	VRAM7		R/W
000632H	LCD - Data register for Segment 17-16	VRAM8		R/W
000633H	LCD - Data register for Segment 19-18	VRAM9		R/W
000634H	LCD - Data register for Segment 21-20	VRAM10		R/W
000635H	LCD - Data register for Segment 23-22	VRAM11		R/W
000636H	LCD - Data register for Segment 25-24	VRAM12		R/W
000637H	LCD - Data register for Segment 27-26	VRAM13		R/W
000638H	LCD - Data register for Segment 29-28	VRAM14		R/W
000639H	LCD - Data register for Segment 31-30	VRAM15		R/W
00063AH	LCD - Data register for Segment 33-32	VRAM16		R/W
00063BH	LCD - Data register for Segment 35-34	VRAM17		R/W
00063CH	LCD - Data register for Segment 37-36	VRAM18		R/W
00063DH	LCD - Data register for Segment 39-38	VRAM19		R/W
00063EH	LCD - Data register for Segment 41-40	VRAM20		R/W
00063FH	LCD - Data register for Segment 43-42	VRAM21		R/W
000640H	LCD - Data register for Segment 45-44	VRAM22		R/W
000641H	LCD - Data register for Segment 47-46	VRAM23		R/W
000642H	LCD - Data register for Segment 49-48	VRAM24		R/W

# MB96370 Series

## I/O map MB96(F)37x (27 of 34)

Address	Register	Abbreviation 8-bit access	Abbreviation 16-bit access	Access
000643 <sub>H</sub>	LCD - Data register for Segment 51-50	VRAM25		R/W
000644 <sub>H</sub>	LCD - Data register for Segment 53-52	VRAM26		R/W
000645 <sub>H</sub>	LCD - Data register for Segment 55-54	VRAM27		R/W
000646 <sub>H</sub>	LCD - Data register for Segment 57-56	VRAM28		R/W
000647 <sub>H</sub>	LCD - Data register for Segment 59-58	VRAM29		R/W
000648 <sub>H</sub>	LCD - Data register for Segment 61-60	VRAM30		R/W
000649 <sub>H</sub>	LCD - Data register for Segment 63-62	VRAM31		R/W
00064A <sub>H</sub>	LCD - Data register for Segment 65-64	VRAM32		R/W
00064B <sub>H</sub>	LCD - Data register for Segment 67-66	VRAM33		R/W
00064C <sub>H</sub>	LCD - Data register for Segment 69-68	VRAM34		R/W
00064D <sub>H</sub>	LCD - Data register for Segment 71-70	VRAM35		R/W
00064E <sub>H</sub> - 00065F <sub>H</sub>	Reserved			-
000660 <sub>H</sub>	Peripheral Resource Relocation Register 10	PRRR10		R/W
000661 <sub>H</sub>	Peripheral Resource Relocation Register 11	PRRR11		R/W
000662 <sub>H</sub>	Peripheral Resource Relocation Register 12	PRRR12		R/W
000663 <sub>H</sub>	Peripheral Resource Relocation Register 13	PRRR13		W
000664 <sub>H</sub> - 0006DF <sub>H</sub>	Reserved			-
0006E0 <sub>H</sub>	External Bus - Area configuration register 0 Low	EACL0	EAC0	R/W
0006E1 <sub>H</sub>	External Bus - Area configuration register 0 High	EACH0		R/W
0006E2 <sub>H</sub>	External Bus - Area configuration register 1 Low	EACL1	EAC1	R/W
0006E3 <sub>H</sub>	External Bus - Area configuration register 1 High	EACH1		R/W
0006E4 <sub>H</sub>	External Bus - Area configuration register 2 Low	EACL2	EAC2	R/W
0006E5 <sub>H</sub>	External Bus - Area configuration register 2 High	EACH2		R/W
0006E6 <sub>H</sub>	External Bus - Area configuration register 3 Low	EACL3	EAC3	R/W
0006E7 <sub>H</sub>	External Bus - Area configuration register 3 High	EACH3		R/W
0006E8 <sub>H</sub>	External Bus - Area configuration register 4 Low	EACL4	EAC4	R/W
0006E9 <sub>H</sub>	External Bus - Area configuration register 4 High	EACH4		R/W
0006EA <sub>H</sub>	External Bus - Area configuration register 5 Low	EACL5	EAC5	R/W
0006EB <sub>H</sub>	External Bus - Area configuration register 5 High	EACH5		R/W

## I/O map MB96(F)37x (28 of 34)

Address	Register	Abbreviation 8-bit access	Abbreviation 16-bit access	Access
0006EC <sub>H</sub>	External Bus - Area select register 2	EAS2		R/W
0006ED <sub>H</sub>	External Bus - Area select register 3	EAS3		R/W
0006EE <sub>H</sub>	External Bus - Area select register 4	EAS4		R/W
0006EF <sub>H</sub>	External Bus - Area select register 5	EAS5		R/W
0006F0 <sub>H</sub>	External Bus - Mode register	EBM		R/W
0006F1 <sub>H</sub>	External Bus - Clock and Function register	EBCF		R/W
0006F2 <sub>H</sub>	External Bus - Address output enable register 0	EBAE0		R/W
0006F3 <sub>H</sub>	External Bus - Address output enable register 1	EBAE1		R/W
0006F4 <sub>H</sub>	External Bus - Address output enable register 2	EBAE2		R/W
0006F5 <sub>H</sub>	External Bus - Control signal register	EBCS		R/W
0006F6 <sub>H</sub> - 0006FF <sub>H</sub>	Reserved			-
000700 <sub>H</sub>	CAN0 - Control register Low	CTRLRL0	CTRLR0	R/W
000701 <sub>H</sub>	CAN0 - Control register High (reserved)	CTRLRH0		R
000702 <sub>H</sub>	CAN0 - Status register Low	STATRL0	STATR0	R/W
000703 <sub>H</sub>	CAN0 - Status register High (reserved)	STATRH0		R
000704 <sub>H</sub>	CAN0 - Error Counter Low (Transmit)	ERRCNTL0	ERRCNT0	R
000705 <sub>H</sub>	CAN0 - Error Counter High (Receive)	ERRCNTH0		R
000706 <sub>H</sub>	CAN0 - Bit Timing Register Low	BTRL0	BTR0	R/W
000707 <sub>H</sub>	CAN0 - Bit Timing Register High	BTRH0		R/W
000708 <sub>H</sub>	CAN0 - Interrupt Register Low	INTRL0	INTR0	R
000709 <sub>H</sub>	CAN0 - Interrupt Register High	INTRH0		R
00070A <sub>H</sub>	CAN0 - Test Register Low	TESTRL0	TESTR0	R/W
00070B <sub>H</sub>	CAN0 - Test Register High (reserved)	TESTRH0		R
00070C <sub>H</sub>	CAN0 - BRP Extension register Low	BRPERL0	BRPER0	R/W
00070D <sub>H</sub>	CAN0 - BRP Extension register High (reserved)	BRPERH0		R
00070E <sub>H</sub> - 00070F <sub>H</sub>	Reserved			-
000710 <sub>H</sub>	CAN0 - IF1 Command request register Low	IF1CREQL0	IF1CREQ0	R/W
000711 <sub>H</sub>	CAN0 - IF1 Command request register High	IF1CREQH0		R/W
000712 <sub>H</sub>	CAN0 - IF1 Command Mask register Low	IF1CMSKL0	IF1CMSK0	R/W

# MB96370 Series

## I/O map MB96(F)37x (29 of 34)

Address	Register	Abbreviation 8-bit access	Abbreviation 16-bit access	Access
000713 <sub>H</sub>	CAN0 - IF1 Command Mask register High (reserved)	IF1CMSKH0		R
000714 <sub>H</sub>	CAN0 - IF1 Mask 1 Register Low	IF1MSK1L0	IF1MSK10	R/W
000715 <sub>H</sub>	CAN0 - IF1 Mask 1 Register High	IF1MSK1H0		R/W
000716 <sub>H</sub>	CAN0 - IF1 Mask 2 Register Low	IF1MSK2L0	IF1MSK20	R/W
000717 <sub>H</sub>	CAN0 - IF1 Mask 2 Register High	IF1MSK2H0		R/W
000718 <sub>H</sub>	CAN0 - IF1 Arbitration 1 Register Low	IF1ARB1L0	IF1ARB10	R/W
000719 <sub>H</sub>	CAN0 - IF1 Arbitration 1 Register High	IF1ARB1H0		R/W
00071A <sub>H</sub>	CAN0 - IF1 Arbitration 2 Register Low	IF1ARB2L0	IF1ARB20	R/W
00071B <sub>H</sub>	CAN0 - IF1 Arbitration 2 Register High	IF1ARB2H0		R/W
00071C <sub>H</sub>	CAN0 - IF1 Message Control Register Low	IF1MCTRL0	IF1MCTR0	R/W
00071D <sub>H</sub>	CAN0 - IF1 Message Control Register High	IF1MCTRH0		R/W
00071E <sub>H</sub>	CAN0 - IF1 Data A1 Low	IF1DTA1L0	IF1DTA10	R/W
00071F <sub>H</sub>	CAN0 - IF1 Data A1 High	IF1DTA1H0		R/W
000720 <sub>H</sub>	CAN0 - IF1 Data A2 Low	IF1DTA2L0	IF1DTA20	R/W
000721 <sub>H</sub>	CAN0 - IF1 Data A2 High	IF1DTA2H0		R/W
000722 <sub>H</sub>	CAN0 - IF1 Data B1 Low	IF1DTB1L0	IF1DTB10	R/W
000723 <sub>H</sub>	CAN0 - IF1 Data B1 High	IF1DTB1H0		R/W
000724 <sub>H</sub>	CAN0 - IF1 Data B2 Low	IF1DTB2L0	IF1DTB20	R/W
000725 <sub>H</sub>	CAN0 - IF1 Data B2 High	IF1DTB2H0		R/W
000726 <sub>H</sub> - 00073F <sub>H</sub>	Reserved			-
000740 <sub>H</sub>	CAN0 - IF2 Command request register Low	IF2CREQL0	IF2CREQ0	R/W
000741 <sub>H</sub>	CAN0 - IF2 Command request register High	IF2CREQH0		R/W
000742 <sub>H</sub>	CAN0 - IF2 Command Mask register Low	IF2CMSKL0	IF2CMSK0	R/W
000743 <sub>H</sub>	CAN0 - IF2 Command Mask register High (reserved)	IF2CMSKH0		R
000744 <sub>H</sub>	CAN0 - IF2 Mask 1 Register Low	IF2MSK1L0	IF2MSK10	R/W
000745 <sub>H</sub>	CAN0 - IF2 Mask 1 Register High	IF2MSK1H0		R/W
000746 <sub>H</sub>	CAN0 - IF2 Mask 2 Register Low	IF2MSK2L0	IF2MSK20	R/W
000747 <sub>H</sub>	CAN0 - IF2 Mask 2 Register High	IF2MSK2H0		R/W

## I/O map MB96(F)37x (30 of 34)

Address	Register	Abbreviation 8-bit access	Abbreviation 16-bit access	Access
000748 <sub>H</sub>	CAN0 - IF2 Arbitration 1 Register Low	IF2ARB1L0	IF2ARB10	R/W
000749 <sub>H</sub>	CAN0 - IF2 Arbitration 1 Register High	IF2ARB1H0		R/W
00074A <sub>H</sub>	CAN0 - IF2 Arbitration 2 Register Low	IF2ARB2L0	IF2ARB20	R/W
00074B <sub>H</sub>	CAN0 - IF2 Arbitration 2 Register High	IF2ARB2H0		R/W
00074C <sub>H</sub>	CAN0 - IF2 Message Control Register Low	IF2MCTRL0	IF2MCTR0	R/W
00074D <sub>H</sub>	CAN0 - IF2 Message Control Register High	IF2MCTRH0		R/W
00074E <sub>H</sub>	CAN0 - IF2 Data A1 Low	IF2DTA1L0	IF2DTA10	R/W
00074F <sub>H</sub>	CAN0 - IF2 Data A1 High	IF2DTA1H0		R/W
000750 <sub>H</sub>	CAN0 - IF2 Data A2 Low	IF2DTA2L0	IF2DTA20	R/W
000751 <sub>H</sub>	CAN0 - IF2 Data A2 High	IF2DTA2H0		R/W
000752 <sub>H</sub>	CAN0 - IF2 Data B1 Low	IF2DTB1L0	IF2DTB10	R/W
000753 <sub>H</sub>	CAN0 - IF2 Data B1 High	IF2DTB1H0		R/W
000754 <sub>H</sub>	CAN0 - IF2 Data B2 Low	IF2DTB2L0	IF2DTB20	R/W
000755 <sub>H</sub>	CAN0 - IF2 Data B2 High	IF2DTB2H0		R/W
000756 <sub>H</sub> - 00077F <sub>H</sub>	Reserved			-
000780 <sub>H</sub>	CAN0 - Transmission Request 1 Register Low	TREQR1L0	TREQR10	R
000781 <sub>H</sub>	CAN0 - Transmission Request 1 Register High	TREQR1H0		R
000782 <sub>H</sub>	CAN0 - Transmission Request 2 Register Low	TREQR2L0	TREQR20	R
000783 <sub>H</sub>	CAN0 - Transmission Request 2 Register High	TREQR2H0		R
000784 <sub>H</sub> - 00078F <sub>H</sub>	Reserved			-
000790 <sub>H</sub>	CAN0 - New Data 1 Register Low	NEWDT1L0	NEWDT10	R
000791 <sub>H</sub>	CAN0 - New Data 1 Register High	NEWDT1H0		R
000792 <sub>H</sub>	CAN0 - New Data 2 Register Low	NEWDT2L0	NEWDT20	R
000793 <sub>H</sub>	CAN0 - New Data 2 Register High	NEWDT2H0		R
000794 <sub>H</sub> - 00079F <sub>H</sub>	Reserved			-
0007A0 <sub>H</sub>	CAN0 - Interrupt Pending 1 Register Low	INTPND1L0	INTPND10	R
0007A1 <sub>H</sub>	CAN0 - Interrupt Pending 1 Register High	INTPND1H0		R
0007A2 <sub>H</sub>	CAN0 - Interrupt Pending 2 Register Low	INTPND2L0	INTPND20	R

# MB96370 Series

## I/O map MB96(F)37x (31 of 34)

Address	Register	Abbreviation 8-bit access	Abbreviation 16-bit access	Access
0007A3 <sub>H</sub>	CAN0 - Interrupt Pending 2 Register High	INTPND2H0		R
0007A4 <sub>H</sub> - 0007AF <sub>H</sub>	Reserved			-
0007B0 <sub>H</sub>	CAN0 - Message Valid 1 Register Low	MSGVAL1L0	MSGVAL10	R
0007B1 <sub>H</sub>	CAN0 - Message Valid 1 Register High	MSGVAL1H0		R
0007B2 <sub>H</sub>	CAN0 - Message Valid 2 Register Low	MSGVAL2L0	MSGVAL20	R
0007B3 <sub>H</sub>	CAN0 - Message Valid 2 Register High	MSGVAL2H0		R
0007B4 <sub>H</sub> - 0007CD <sub>H</sub>	Reserved			-
0007CE <sub>H</sub>	CAN0 - Output enable register	COER0		R/W
0007CF <sub>H</sub>	Reserved			-
0007D0 <sub>H</sub>	SG0 - Sound Generator Control Register Low	SGCRL0	SGCR0	R/W
0007D1 <sub>H</sub>	SG0 - Sound Generator Control Register High	SGCRH0		R/W
0007D2 <sub>H</sub>	SG0 - Sound Generator Frequency Register	SGFR0		R/W
0007D3 <sub>H</sub>	SG0 - Sound Generator Amplitude Register	SGAR0		R/W
0007D4 <sub>H</sub>	SG0 - Sound Generator Decrement Register	SGDR0		R/W
0007D5 <sub>H</sub>	SG0 - Sound Generator Tone Register	SGTR0		R/W
0007D6 <sub>H</sub>	SG1 - Sound Generator Control Register Low	SGCRL1	SGCR1	R/W
0007D7 <sub>H</sub>	SG1 - Sound Generator Control Register High	SGCRH1		R/W
0007D8 <sub>H</sub>	SG1 - Sound Generator Frequency Register	SGFR1		R/W
0007D9 <sub>H</sub>	SG1 - Sound Generator Amplitude Register	SGAR1		R/W
0007DA <sub>H</sub>	SG1 - Sound Generator Decrement Register	SGDR1		R/W
0007DB <sub>H</sub>	SG1 - Sound Generator Tone Register	SGTR1		R/W
0007DC <sub>H</sub> - 0007FF <sub>H</sub>	Reserved			-
000800 <sub>H</sub>	CAN1 - Control register Low	CTRLRL1	CTRLR1	R/W
000801 <sub>H</sub>	CAN1 - Control register High (reserved)	CTRLRH1		R
000802 <sub>H</sub>	CAN1 - Status register Low	STATRL1	STATR1	R/W
000803 <sub>H</sub>	CAN1 - Status register High (reserved)	STATRH1		R
000804 <sub>H</sub>	CAN1 - Error Counter Low (Transmit)	ERRCNTL1	ERRCNT1	R
000805 <sub>H</sub>	CAN1 - Error Counter High (Receive)	ERRCNTH1		R

## I/O map MB96(F)37x (32 of 34)

Address	Register	Abbreviation 8-bit access	Abbreviation 16-bit access	Access
000806 <sub>H</sub>	CAN1 - Bit Timing Register Low	BTRL1	BTR1	R/W
000807 <sub>H</sub>	CAN1 - Bit Timing Register High	BTRH1		R/W
000808 <sub>H</sub>	CAN1 - Interrupt Register Low	INTRL1	INTR1	R
000809 <sub>H</sub>	CAN1 - Interrupt Register High	INTRH1		R
00080A <sub>H</sub>	CAN1 - Test Register Low	TESTRL1	TESTR1	R/W
00080B <sub>H</sub>	CAN1 - Test Register High (reserved)	TESTRH1		R
00080C <sub>H</sub>	CAN1 - BRP Extension register Low	BRPERL1	BRPER1	R/W
00080D <sub>H</sub>	CAN1 - BRP Extension register High (reserved)	BRPERH1		R
00080E <sub>H</sub> - 00080F <sub>H</sub>	Reserved			-
000810 <sub>H</sub>	CAN1 - IF1 Command request register Low	IF1CREQL1	IF1CREQ1	R/W
000811 <sub>H</sub>	CAN1 - IF1 Command request register High	IF1CREQH1		R/W
000812 <sub>H</sub>	CAN1 - IF1 Command Mask register Low	IF1CMSKL1	IF1CMSK1	R/W
000813 <sub>H</sub>	CAN1 - IF1 Command Mask register High (re- served)	IF1CMSKH1		R
000814 <sub>H</sub>	CAN1 - IF1 Mask 1 Register Low	IF1MSK1L1	IF1MSK11	R/W
000815 <sub>H</sub>	CAN1 - IF1 Mask 1 Register High	IF1MSK1H1		R/W
000816 <sub>H</sub>	CAN1 - IF1 Mask 2 Register Low	IF1MSK2L1	IF1MSK21	R/W
000817 <sub>H</sub>	CAN1 - IF1 Mask 2 Register High	IF1MSK2H1		R/W
000818 <sub>H</sub>	CAN1 - IF1 Arbitration 1 Register Low	IF1ARB1L1	IF1ARB11	R/W
000819 <sub>H</sub>	CAN1 - IF1 Arbitration 1 Register High	IF1ARB1H1		R/W
00081A <sub>H</sub>	CAN1 - IF1 Arbitration 2 Register Low	IF1ARB2L1	IF1ARB21	R/W
00081B <sub>H</sub>	CAN1 - IF1 Arbitration 2 Register High	IF1ARB2H1		R/W
00081C <sub>H</sub>	CAN1 - IF1 Message Control Register Low	IF1MCTRL1	IF1MCTR1	R/W
00081D <sub>H</sub>	CAN1 - IF1 Message Control Register High	IF1MCTRH1		R/W
00081E <sub>H</sub>	CAN1 - IF1 Data A1 Low	IF1DTA1L1	IF1DTA11	R/W
00081F <sub>H</sub>	CAN1 - IF1 Data A1 High	IF1DTA1H1		R/W
000820 <sub>H</sub>	CAN1 - IF1 Data A2 Low	IF1DTA2L1	IF1DTA21	R/W
000821 <sub>H</sub>	CAN1 - IF1 Data A2 High	IF1DTA2H1		R/W
000822 <sub>H</sub>	CAN1 - IF1 Data B1 Low	IF1DTB1L1	IF1DTB11	R/W
000823 <sub>H</sub>	CAN1 - IF1 Data B1 High	IF1DTB1H1		R/W

# MB96370 Series

## I/O map MB96(F)37x (33 of 34)

Address	Register	Abbreviation 8-bit access	Abbreviation 16-bit access	Access
000824 <sub>H</sub>	CAN1 - IF1 Data B2 Low	IF1DTB2L1	IF1DTB21	R/W
000825 <sub>H</sub>	CAN1 - IF1 Data B2 High	IF1DTB2H1		R/W
000826 <sub>H</sub> - 00083F <sub>H</sub>	Reserved			-
000840 <sub>H</sub>	CAN1 - IF2 Command request register Low	IF2CREQL1	IF2CREQ1	R/W
000841 <sub>H</sub>	CAN1 - IF2 Command request register High	IF2CREQH1		R/W
000842 <sub>H</sub>	CAN1 - IF2 Command Mask register Low	IF2CMSKL1	IF2CMSK1	R/W
000843 <sub>H</sub>	CAN1 - IF2 Command Mask register High (re- served)	IF2CMSKH1		R
000844 <sub>H</sub>	CAN1 - IF2 Mask 1 Register Low	IF2MSK1L1	IF2MSK11	R/W
000845 <sub>H</sub>	CAN1 - IF2 Mask 1 Register High	IF2MSK1H1		R/W
000846 <sub>H</sub>	CAN1 - IF2 Mask 2 Register Low	IF2MSK2L1	IF2MSK21	R/W
000847 <sub>H</sub>	CAN1 - IF2 Mask 2 Register High	IF2MSK2H1		R/W
000848 <sub>H</sub>	CAN1 - IF2 Arbitration 1 Register Low	IF2ARB1L1	IF2ARB11	R/W
000849 <sub>H</sub>	CAN1 - IF2 Arbitration 1 Register High	IF2ARB1H1		R/W
00084A <sub>H</sub>	CAN1 - IF2 Arbitration 2 Register Low	IF2ARB2L1	IF2ARB21	R/W
00084B <sub>H</sub>	CAN1 - IF2 Arbitration 2 Register High	IF2ARB2H1		R/W
00084C <sub>H</sub>	CAN1 - IF2 Message Control Register Low	IF2MCTRL1	IF2MCTR1	R/W
00084D <sub>H</sub>	CAN1 - IF2 Message Control Register High	IF2MCTRH1		R/W
00084E <sub>H</sub>	CAN1 - IF2 Data A1 Low	IF2DTA1L1	IF2DTA11	R/W
00084F <sub>H</sub>	CAN1 - IF2 Data A1 High	IF2DTA1H1		R/W
000850 <sub>H</sub>	CAN1 - IF2 Data A2 Low	IF2DTA2L1	IF2DTA21	R/W
000851 <sub>H</sub>	CAN1 - IF2 Data A2 High	IF2DTA2H1		R/W
000852 <sub>H</sub>	CAN1 - IF2 Data B1 Low	IF2DTB1L1	IF2DTB11	R/W
000853 <sub>H</sub>	CAN1 - IF2 Data B1 High	IF2DTB1H1		R/W
000854 <sub>H</sub>	CAN1 - IF2 Data B2 Low	IF2DTB2L1	IF2DTB21	R/W
000855 <sub>H</sub>	CAN1 - IF2 Data B2 High	IF2DTB2H1		R/W
000856 <sub>H</sub> - 00087F <sub>H</sub>	Reserved			-
000880 <sub>H</sub>	CAN1 - Transmission Request 1 Register Low	TREQR1L1	TREQR11	R
000881 <sub>H</sub>	CAN1 - Transmission Request 1 Register High	TREQR1H1		R



## I/O map MB96(F)37x (34 of 34)

Address	Register	Abbreviation 8-bit access	Abbreviation 16-bit access	Access
000882 <sub>H</sub>	CAN1 - Transmission Request 2 Register Low	TREQR2L1	TREQR21	R
000883 <sub>H</sub>	CAN1 - Transmission Request 2 Register High	TREQR2H1		R
000884 <sub>H</sub> - 00088F <sub>H</sub>	Reserved			-
000890 <sub>H</sub>	CAN1 - New Data 1 Register Low	NEWDT1L1	NEWDT11	R
000891 <sub>H</sub>	CAN1 - New Data 1 Register High	NEWDT1H1		R
000892 <sub>H</sub>	CAN1 - New Data 2 Register Low	NEWDT2L1	NEWDT21	R
000893 <sub>H</sub>	CAN1 - New Data 2 Register High	NEWDT2H1		R
000894 <sub>H</sub> - 00089F <sub>H</sub>	Reserved			-
0008A0 <sub>H</sub>	CAN1 - Interrupt Pending 1 Register Low	INTPND1L1	INTPND11	R
0008A1 <sub>H</sub>	CAN1 - Interrupt Pending 1 Register High	INTPND1H1		R
0008A2 <sub>H</sub>	CAN1 - Interrupt Pending 2 Register Low	INTPND2L1	INTPND21	R
0008A3 <sub>H</sub>	CAN1 - Interrupt Pending 2 Register High	INTPND2H1		R
0008A4 <sub>H</sub> - 0008AF <sub>H</sub>	Reserved			-
0008B0 <sub>H</sub>	CAN1 - Message Valid 1 Register Low	MSGVAL1L1	MSGVAL11	R
0008B1 <sub>H</sub>	CAN1 - Message Valid 1 Register High	MSGVAL1H1		R
0008B2 <sub>H</sub>	CAN1 - Message Valid 2 Register Low	MSGVAL2L1	MSGVAL21	R
0008B3 <sub>H</sub>	CAN1 - Message Valid 2 Register High	MSGVAL2H1		R
0008B4 <sub>H</sub> - 0008CD <sub>H</sub>	Reserved			-
0008CE <sub>H</sub>	CAN1 - Output enable register	COER1		R/W
0008CF <sub>H</sub> - 000BFF <sub>H</sub>	Reserved			-

Note: Any write access to reserved addresses in the I/O map should not be performed. A read access to a reserved address results in reading 'X'.

Registers of resources which are described in this table, but which are not supported by the device, should also be handled as "Reserved".

# MB96370 Series

## ■ INTERRUPT VECTOR TABLE

Interrupt vector table MB96(F)37x (1 of 3)

Vector number	Offset in vector table	Vector name	Cleared by DMA	Index in ICR to program	Description
0	3FC <sub>H</sub>	CALLV0	No	-	
1	3F8 <sub>H</sub>	CALLV1	No	-	
2	3F4 <sub>H</sub>	CALLV2	No	-	
3	3F0 <sub>H</sub>	CALLV3	No	-	
4	3EC <sub>H</sub>	CALLV4	No	-	
5	3E8 <sub>H</sub>	CALLV5	No	-	
6	3E4 <sub>H</sub>	CALLV6	No	-	
7	3E0 <sub>H</sub>	CALLV7	No	-	
8	3DC <sub>H</sub>	RESET	No	-	
9	3D8 <sub>H</sub>	INT9	No	-	
10	3D4 <sub>H</sub>	EXCEPTION	No	-	
11	3D0 <sub>H</sub>	NMI	No	-	Non-Maskable Interrupt
12	3CC <sub>H</sub>	DLY	No	12	Delayed Interrupt
13	3C8 <sub>H</sub>	RC_TIMER	No	13	RC Timer
14	3C4 <sub>H</sub>	MC_TIMER	No	14	Main Clock Timer
15	3C0 <sub>H</sub>	SC_TIMER	No	15	Sub Clock Timer
16	3BC <sub>H</sub>	RESERVED	No	16	Reserved
17	3B8 <sub>H</sub>	EXTINT0	Yes	17	External Interrupt 0
18	3B4 <sub>H</sub>	EXTINT1	Yes	18	External Interrupt 1
19	3B0 <sub>H</sub>	EXTINT2	Yes	19	External Interrupt 2
20	3AC <sub>H</sub>	EXTINT3	Yes	20	External Interrupt 3
21	3A8 <sub>H</sub>	EXTINT4	Yes	21	External Interrupt 4
22	3A4 <sub>H</sub>	EXTINT5	Yes	22	External Interrupt 5
23	3A0 <sub>H</sub>	EXTINT6	Yes	23	External Interrupt 6
24	39C <sub>H</sub>	EXTINT7	Yes	24	External Interrupt 7
25	398 <sub>H</sub>	CAN0	No	25	CAN Controller 0
26	394 <sub>H</sub>	CAN1	No	26	CAN Controller 1
27	390 <sub>H</sub>	PPG0	Yes	27	Programmable Pulse Generator 0
28	38C <sub>H</sub>	PPG1	Yes	28	Programmable Pulse Generator 1
29	388 <sub>H</sub>	PPG2	Yes	29	Programmable Pulse Generator 2
30	384 <sub>H</sub>	PPG3	Yes	30	Programmable Pulse Generator 3
31	380	PPG4	Yes	31	Programmable Pulse Generator 4
32	37C <sub>H</sub>	PPG5	Yes	32	Programmable Pulse Generator 5

Interrupt vector table MB96(F)37x (2 of 3)

Vector number	Offset in vector table	Vector name	Cleared by DMA	Index in ICR to program	Description
33	378H	PPG6	Yes	33	Programmable Pulse Generator 6
34	374H	PPG7	Yes	34	Programmable Pulse Generator 7
35	370H	RLT0	Yes	35	Reload Timer 0
36	36CH	RLT1	Yes	36	Reload Timer 1
37	368H	RLT2	Yes	37	Reload Timer 2
38	364H	RLT3	Yes	38	Reload Timer 3
39	360H	PPGRLT	Yes	39	Reload Timer 6 - dedicated for PPG
40	35CH	ICU0	Yes	40	Input Capture Unit 0
41	358H	ICU1	Yes	41	Input Capture Unit 1
42	354H	ICU2	Yes	42	Input Capture Unit 2
43	350H	ICU3	Yes	43	Input Capture Unit 3
44	34CH	ICU4	Yes	44	Input Capture Unit 4
45	348H	ICU5	Yes	45	Input Capture Unit 5
46	344H	ICU6	Yes	46	Input Capture Unit 6
47	340H	ICU7	Yes	47	Input Capture Unit 7
48	33CH	OCU0	Yes	48	Output Compare Unit 0
49	338H	OCU1	Yes	49	Output Compare Unit 1
50	334H	OCU2	Yes	50	Output Compare Unit 2
51	330H	OCU3	Yes	51	Output Compare Unit 3
52	32CH	FRT0	Yes	52	Free Running Timer 0
53	328H	FRT1	Yes	53	Free Running Timer 1
54	324H	RTC0	No	54	Real Timer Clock
55	320H	CAL0	No	55	Clock Calibration Unit
56	31CH	SG0	No	56	Sound Generator 0
57	318H	SG1	No	57	Sound Generator 1
58	314H	IIC0	Yes	58	I <sup>2</sup> C interface 0
59	310H	ADC0	Yes	59	A/D Converter
60	30CH	ALARM0	No	60	Alarm Comparator 0
61	308H	ALARM1	No	61	Alarm Comparator 1
62	304H	LINR0	Yes	62	LIN USART 0 RX
63	300H	LINT0	Yes	63	LIN USART 0 TX
64	2FC <sub>H</sub>	LINR1	Yes	64	LIN USART 1 RX
65	2F8 <sub>H</sub>	LINT1	Yes	65	LIN USART 1 TX
66	2F4 <sub>H</sub>	LINR2	Yes	66	LIN USART 2 RX
67	2F0 <sub>H</sub>	LINT2	Yes	67	LIN USART 2 TX

# MB96370 Series

Interrupt vector table MB96(F)37x (3 of 3)

Vector number	Offset in vector table	Vector name	Cleared by DMA	Index in ICR to program	Description
68	2EC <sub>H</sub>	LINR4	Yes	68	LIN USART 4 RX
69	2E8 <sub>H</sub>	LINT4	Yes	69	LIN USART 4 TX
70	2E4 <sub>H</sub>	LINR5	Yes	70	LIN USART 5 RX
71	2E0 <sub>H</sub>	LINT5	Yes	71	LIN USART 5 TX
72	2DC <sub>H</sub>	FLASH_A	No	72	Flash memory A (only Flash devices)
73	2D8 <sub>H</sub>	FLASH_B	No	73	Flash memory B (only Flash devices with Flash B)
74	2D4 <sub>H</sub>	PPG8	Yes	74	Programmable Pulse Generator 8
75	2D0 <sub>H</sub>	PPG9	Yes	75	Programmable Pulse Generator 9
76	2CC <sub>H</sub>	PPG10	Yes	76	Programmable Pulse Generator 10
77	2C8 <sub>H</sub>	PPG11	Yes	77	Programmable Pulse Generator 11
78	2C4 <sub>H</sub>	OCU4	Yes	78	Output Compare Unit 4
79	2C0 <sub>H</sub>	OCU5	Yes	79	Output Compare Unit 5
80	2BC <sub>H</sub>	IIC1	Yes	80	I <sup>2</sup> C Interface 1
81	2B8 <sub>H</sub>	LINR3	Yes	81	LIN USART 3 RX
82	2B4 <sub>H</sub>	LINT3	Yes	82	LIN USART 3 TX

## ■ HANDLING DEVICES

Special care is required for the following when handling the device:

- Latch-up prevention
- Unused pins handling
- External clock usage
- Unused sub clock signal
- Notes on PLL clock mode operation
- Power supply pins ( $V_{CC}/V_{SS}$ )
- Crystal oscillator circuit
- Turn on sequence of power supply to A/D converter and analog inputs
- Pin handling when not using the A/D converter
- Notes on energization
- Stabilization of power supply voltage
- SMC power supply pins
- Serial communication

### 1. Latch-up prevention

CMOS IC chips may suffer latch-up under the following conditions:

- A voltage higher than  $V_{CC}$  or lower than  $V_{SS}$  is applied to an input or output pin.
- A voltage higher than the rated voltage is applied between  $V_{CC}$  pins and  $V_{SS}$  pins.
- The  $AV_{CC}$  power supply is applied before the  $V_{CC}$  voltage.

Latch-up may increase the power supply current dramatically, causing thermal damages to the device.

For the same reason, extra care is required to not let the analog power-supply voltage ( $AV_{CC}$ ,  $AVRH$ ) exceed the digital power-supply voltage.

### 2. Unused pins handling

Unused input pins can be left open when the input is disabled (corresponding bit of Port Input Enable register  $PIER = 0$ ).

Leaving unused input pins open when the input is enabled may result in misbehavior and possible permanent damage of the device. They must therefore be pulled up or pulled down through resistors. To prevent latch-up, those resistors should be more than 2 k $\Omega$ .

Unused bidirectional pins can be set either to the output state and be then left open, or to the input state with either input disabled or external pull-up/pull-down resistor as described above.

### 3. External clock usage

The permitted frequency range of an external clock depends on the oscillator type and configuration. See AC Characteristics for detailed modes and frequency limits. Single and opposite phase external clocks must be connected as follows:

#### 1. Single phase external clock

- When using a single phase external clock, X0 pin must be driven and X1 pin left open.

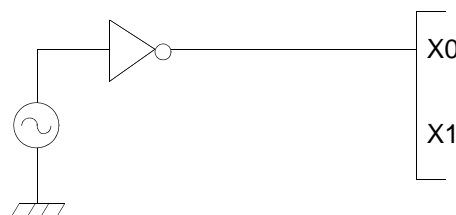

## 2. Opposite phase external clock

- When using an opposite phase external clock, X1 (X1A) must be supplied with a clock signal which has the opposite phase to the X0 (X0A) pins.

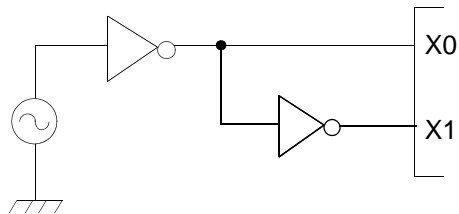

## 4. Unused sub clock signal

If the pins X0A and X1A are not connected to an oscillator, a pull-down resistor must be connected on the X0A pin and the X1A pin must be left open.

## 5. Notes on PLL clock mode operation

If the PLL clock mode is selected and no external oscillator is operating or no external clock is supplied, the microcontroller attempts to work with the free oscillating PLL. Performance of this operation, however, cannot be guaranteed.

## 6. Power supply pins ( $V_{CC}/V_{SS}$ )

It is required that all  $V_{CC}$ -level as well as all  $V_{SS}$ -level power supply pins are at the same potential. If there is more than one  $V_{CC}$  or  $V_{SS}$  level, the device may operate incorrectly or be damaged even within the guaranteed operating range.

$V_{CC}$  and  $V_{SS}$  must be connected to the device from the power supply with lowest possible impedance.

As a measure against power supply noise, it is required to connect a bypass capacitor of about 0.1  $\mu\text{F}$  between  $V_{CC}$  and  $V_{SS}$  as close as possible to  $V_{CC}$  and  $V_{SS}$  pins.

## 7. Crystal oscillator and ceramic resonator circuit

Noise at X0, X1 pins or X0A, X1A pins might cause abnormal operation. It is required to provide bypass capacitors with shortest possible distance to X0, X1 pins and X0A, X1A pins, crystal oscillator (or ceramic resonator) and ground lines, and, to the utmost effort, that the lines of oscillation circuit do not cross the lines of other circuits.

It is highly recommended to provide a printed circuit board art work surrounding X0, X1 pins and X0A, X1A pins with a ground area for stabilizing the operation.

It is highly recommended to evaluate the quartz/MCU or resonator/MCU system at the quartz or resonator manufacturer, especially when using low-Q resonators at higher frequencies.

## 8. Turn on sequence of power supply to A/D converter and analog inputs

It is required to turn the A/D converter power supply ( $AV_{CC}$ ,  $AV_{RH}$ ,  $AV_{RL}$ ) and analog inputs ( $AN_n$ ) on after turning the digital power supply ( $V_{CC}$ ) on.

It is also required to turn the digital power off after turning the A/D converter supply and analog inputs off. In this case, the voltage must not exceed  $AV_{RH}$  or  $AV_{CC}$  (turning the analog and digital power supplies simultaneously on or off is acceptable).

## 9. Pin handling when not using the A/D converter

It is required to connect the unused pins of the A/D converter as  $AV_{CC} = V_{CC}$ ,  $AV_{SS} = AV_{RH} = AV_{RL} = V_{SS}$ .

## 10. Notes on Power-on

To prevent malfunction of the internal voltage regulator, supply voltage profile while turning the power supply on should be slower than 50 $\mu\text{s}$  from 0.2 V to 2.7 V.

## 11. Stabilization of power supply voltage

If the power supply voltage varies acutely even within the operation safety range of the  $V_{CC}$  power supply voltage, a malfunction may occur. The  $V_{CC}$  power supply voltage must therefore be stabilized. As stabilization guidelines, the power supply voltage must be stabilized in such a way that  $V_{CC}$  ripple fluctuations (peak to peak value) in the commercial frequencies (50 to 60 Hz) fall within 10% of the standard  $V_{CC}$  power supply voltage and the transient fluctuation rate becomes  $0.1V/\mu s$  or less in instantaneous fluctuation for power supply switching.

## 12. SMC power supply pins

All  $DV_{SS}$  pins must be set to the same level as the  $V_{SS}$  pins.

The  $DV_{CC}$  power supply level can be set independently of the  $V_{CC}$  power supply level. However note that the SMC I/O pin state is undefined if  $DV_{CC}$  is powered on and  $V_{CC}$  is below 3V. To avoid this, we recommend to always power  $V_{CC}$  before  $DV_{CC}$ .

## 13. Serial communication

There is a possibility to receive wrong data due to noise or other causes on the serial communication.

Therefore, design a printed circuit board so as to avoid noise.

Consider receiving of wrong data when designing the system. For example apply a checksum and retransmit the data if an error occurs.

# MB96370 Series

## ■ ELECTRICAL CHARACTERISTICS

### 1. Absolute Maximum Ratings

Parameter	Symbol	Rating		Unit	Remarks
		Min	Max		
Power supply voltage	V <sub>CC</sub>	V <sub>SS</sub> - 0.3	V <sub>SS</sub> + 6.0	V	
	AV <sub>CC</sub>	V <sub>SS</sub> - 0.3	V <sub>SS</sub> + 6.0	V	V <sub>CC</sub> = AV <sub>CC</sub> *1
AD Converter voltage references	AVRH, AVRL	V <sub>SS</sub> - 0.3	V <sub>SS</sub> + 6.0	V	AV <sub>CC</sub> ≥ AVRH, AV <sub>CC</sub> ≥ AVRL, AVRH > AVRL, AVRL ≥ AV <sub>SS</sub>
SMC Power supply	DV <sub>CC</sub>	V <sub>SS</sub> - 0.3	V <sub>SS</sub> + 6.0	V	See *7
LCD power supply voltage	V0 to V3	V <sub>SS</sub> - 0.3	V <sub>SS</sub> + 6.0	V	V0 to V3 must not exceed V <sub>CC</sub>
Input voltage	V <sub>I</sub>	V <sub>SS</sub> - 0.3	V <sub>SS</sub> + 6.0	V	V <sub>I</sub> ≤ (D)V <sub>CC</sub> + 0.3V *2
Output voltage	V <sub>O</sub>	V <sub>SS</sub> - 0.3	V <sub>SS</sub> + 6.0	V	V <sub>O</sub> ≤ (D)V <sub>CC</sub> + 0.3V *2
Maximum Clamp Current	I <sub>CLAMP</sub>	-4.0	+4.0	mA	Applicable to general purpose I/O pins *3
Total Maximum Clamp Current	Σ I <sub>CLAMP</sub>	-	40	mA	Applicable to general purpose I/O pins *3
"L" level maximum output current	I <sub>OL1</sub>	-	15	mA	Normal outputs with driving strength set to 5mA
	I <sub>OLSMC</sub>	-	40	mA	High current outputs with driving strength set to 30mA
"L" level average output current	I <sub>OLAV1</sub>	-	5	mA	Normal outputs with driving strength set to 5mA
	I <sub>OLAVSMC</sub>	-	30	mA	High current outputs with driving strength set to 30mA
"L" level maximum overall output current	ΣI <sub>OL1</sub>	-	100	mA	Normal outputs
	ΣI <sub>OLSMC</sub>	-	330	mA	High current outputs
"L" level average overall output current	ΣI <sub>OLAV1</sub>	-	50	mA	Normal outputs
	ΣI <sub>OLAVSMC</sub>	-	250	mA	High current outputs
"H" level maximum output current	I <sub>OH1</sub>	-	-15	mA	Normal outputs with driving strength set to 5mA
	I <sub>OHSMC</sub>	-	-40	mA	High current outputs with driving strength set to 30mA
"H" level average output current	I <sub>OHAV1</sub>	-	-5	mA	Normal outputs with driving strength set to 5mA
	I <sub>OHAVSMC</sub>	-	-30	mA	High current outputs with driving strength set to 30mA
"H" level maximum overall output current	ΣI <sub>OH1</sub>	-	-100	mA	Normal outputs
	ΣI <sub>OHSMC</sub>	-	-330	mA	High current outputs
"H" level average overall output current	ΣI <sub>OHAV1</sub>	-	-50	mA	Normal outputs
	ΣI <sub>OHASMC</sub>	-	-250	mA	High current outputs



Parameter	Symbol	Rating		Unit	Remarks
		Min	Max		
Permitted Power dissipation (Flash devices) <sup>*4</sup>	P <sub>D</sub>	-	350 <sup>*5</sup>	mW	T <sub>A</sub> =105°C
		-	700 <sup>*5</sup>	mW	T <sub>A</sub> =85°C
		-	960 <sup>*5</sup>	mW	T <sub>A</sub> =70°C
		-	430 <sup>*5</sup>	mW	T <sub>A</sub> =125°C, no Flash program/erase <sup>*6</sup>
		-	780 <sup>*5</sup>	mW	T <sub>A</sub> =105°C, no Flash program/erase <sup>*6</sup>
Operating ambient temperature	T <sub>A</sub>	0	+70	°C	MB96V300B
		-40	+105		
		-40	+125		<sup>*6</sup>
Storage temperature	T <sub>STG</sub>	-55	+150	°C	

- \*1: AV<sub>CC</sub> and V<sub>CC</sub> must be set to the same voltage. It is required that AV<sub>CC</sub> does not exceed V<sub>CC</sub> and that the voltage at the analog inputs does not exceed AV<sub>CC</sub> neither when the power is switched on.
- \*2: V<sub>I</sub> and V<sub>O</sub> should not exceed (D)V<sub>CC</sub> + 0.3 V. V<sub>I</sub> should also not exceed the specified ratings. However if the maximum current to/from a input is limited by some means with external components, the I<sub>CLAMP</sub> rating supersedes the V<sub>I</sub> rating. Input/output voltages of high current ports depend on DV<sub>CC</sub>. Input/output voltages of standard ports depend on V<sub>CC</sub>.
- \*3: • Applicable to all general purpose I/O pins (Pnn\_m) except I/O pins with SEG or COM functionality.  
 • Use within recommended operating conditions.  
 • Use at DC voltage (current)  
 • The +B signal should always be applied a limiting resistance placed between the +B signal and the microcontroller.  
 • The value of the limiting resistance should be set so that when the +B signal is applied the input current to the microcontroller pin does not exceed rated values, either instantaneously or for prolonged periods.  
 • Note that when the microcontroller drive current is low, such as in the power saving modes, the +B input potential may pass through the protective diode and increase the potential at the VCC pin, and this may affect other devices.  
 • Note that if a +B signal is input when the microcontroller power supply is off (not fixed at 0 V), the power supply is provided from the pins, so that incomplete operation may result.  
 • Note that if the +B input is applied during power-on, the power supply is provided from the pins and the resulting supply voltage may not be sufficient to operate the Power reset (except devices with persistent low voltage reset in internal vector mode).  
 • No +B signal must be applied to any LCD I/O pin (including unused SEG/COM pins).

# MB96370 Series

- Sample recommended circuits:

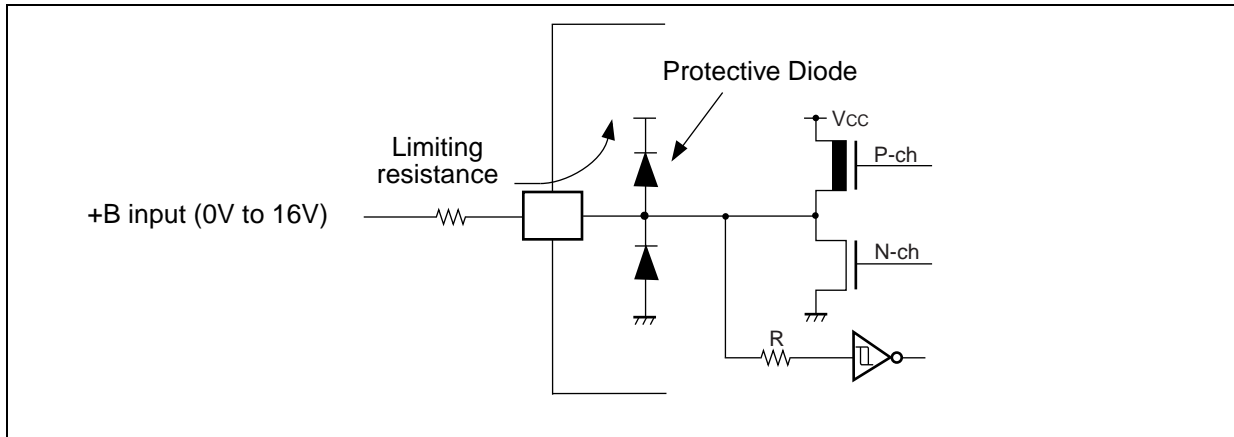

- \*4: The maximum permitted power dissipation depends on the ambient temperature, the air flow velocity and the thermal conductance of the package on the PCB.

The actual power dissipation depends on the customer application and can be calculated as follows:

$$P_D = P_{IO} + P_{INT}$$

$$P_{IO} = \sum (V_{OL} * I_{OL} + V_{OH} * I_{OH}) \text{ (IO load power dissipation, sum is performed on all IO ports)}$$

$$P_{INT} = V_{CC} * (I_{CC} + I_A) \text{ (internal power dissipation)}$$

$I_{CC}$  is the total core current consumption into  $V_{CC}$  as described in the "DC characteristics" and depends on the selected operation mode and clock frequency and the usage of functions like Flash programming or the clock modulator.

$I_A$  is the analog current consumption into  $AV_{CC}$ .

- \*5: Worst case value for a package mounted on single layer PCB at specified  $T_A$  without air flow.
- \*6: Please contact Fujitsu for reliability limitations when using under these conditions.
- \*7: If  $DV_{CC}$  is powered before  $V_{CC}$ , then SMC I/O pins state is undefined. To avoid this, we recommend to always power  $V_{CC}$  before  $DV_{CC}$ . It is not necessary to set  $V_{CC}$  and  $DV_{CC}$  to the same value.

**WARNING:** Semiconductor devices can be permanently damaged by application of stress (voltage, current, temperature, etc.) in excess of absolute maximum ratings. Do not exceed these ratings.

## 2. Recommended Operating Conditions

Parameter	Symbol	Value			Unit	Remarks
		Min	Typ	Max		
Power supply voltage	$V_{CC}, DV_{CC}$	3.0	-	5.5	V	
Smoothing capacitor at C pin	$C_S$	3.5	4.7 - 10	15	$\mu F$	Use a low inductance capacitor (for example X7R ceramic capacitor)

**WARNING:** The recommended operating conditions are required in order to ensure the normal operation of the semiconductor device. All of the device's electrical characteristics are warranted when the device is operated within these ranges.

Always use semiconductor devices within their recommended operating condition ranges. Operation outside these ranges may adversely affect reliability and could result in device failure.

No warranty is made with respect to uses, operating conditions, or combinations not represented on the data sheet. Users considering application outside the listed conditions are advised to contact their FUJITSU representatives beforehand.

# MB96370 Series

## 3. DC characteristics

( $T_A = -40^{\circ}\text{C}$  to  $125^{\circ}\text{C}$ ,  $V_{CC} = AV_{CC} = 3.0\text{V}$  to  $5.5\text{V}$ ,  $DV_{CC} = 3.0\text{V}$  to  $5.5\text{V}$ ,  $V_{SS} = AV_{SS} = DV_{SS} = 0\text{V}$ )

Parameter	Symbol	Pin	Condition	Value			Unit	Remarks
				Min	Typ	Max		
Input H voltage	$V_{IH}$	Port inputs Pnn_m	CMOS Hysteresis 0.8/0.2 input selected	0.8 $V_{CC}$	-	(D) $V_{CC}$ + 0.3	V	
			CMOS Hysteresis 0.7/0.3 input selected	0.7 $V_{CC}$	-	(D) $V_{CC}$ + 0.3	V	(D) $V_{CC} \geq 4.5\text{V}$
				0.74 $V_{CC}$	-	(D) $V_{CC}$ + 0.3	V	(D) $V_{CC} < 4.5\text{V}$
			AUTOMOTIVE Hysteresis input selected	0.8 $V_{CC}$	-	(D) $V_{CC}$ + 0.3	V	
	TTL input selected	2.0	-	(D) $V_{CC}$ + 0.3	V			
	$V_{IH\text{X}0\text{F}}$	X0	External clock in "Fast Clock Input mode"	0.8 $V_{CC}$	-	$V_{CC} +$ 0.3	V	
	$V_{IH\text{X}0\text{S}}$	X0,X1, X0A,X1A	External clock in "oscillation mode"	2.5	-	$V_{CC} +$ 0.3	V	
	$V_{IHR}$	RSTX	-	0.8 $V_{CC}$	-	$V_{CC} +$ 0.3	V	CMOS Hysteresis input
$V_{IHM}$	MD2-MD0	-	$V_{CC} -$ 0.3	-	$V_{CC} +$ 0.3	V		
Input L voltage	$V_{IL}$	Port inputs Pnn_m	CMOS Hysteresis 0.8/0.2 input selected	$V_{SS} -$ 0.3	-	0.2 (D) $V_{CC}$	V	
			CMOS Hysteresis 0.7/0.3 input selected	$V_{SS} -$ 0.3	-	0.3 (D) $V_{CC}$	V	
				$V_{SS} -$ 0.3	-	0.5 (D) $V_{CC}$	V	(D) $V_{CC} \geq 4.5\text{V}$
			AUTOMOTIVE Hysteresis input selected	$V_{SS} -$ 0.3	-	0.46 (D) $V_{CC}$		(D) $V_{CC} < 4.5\text{V}$
	TTL input selected	$V_{SS} -$ 0.3	-	0.8	V			
	$V_{IL\text{X}0\text{F}}$	X0	External clock in "Fast Clock Input mode"	$V_{SS} -$ 0.3	-	0.2 $V_{CC}$	V	
	$V_{IL\text{X}0\text{S}}$	X0,X1, X0A,X1A	External clock in "oscillation mode"	$V_{SS} -$ 0.3	-	0.4	V	
	$V_{ILR}$	RSTX	-	$V_{SS} -$ 0.3	-	0.2 $V_{CC}$	V	CMOS Hysteresis input
	$V_{ILM}$	MD2-MD0	-	$V_{SS} -$ 0.3	-	$V_{SS} +$ 0.3	V	

# MB96370 Series

(T<sub>A</sub> = -40°C to 125°C, V<sub>CC</sub> = AV<sub>CC</sub> = 3.0V to 5.5V, DV<sub>CC</sub> = 3.0V to 5.5V, V<sub>SS</sub> = AV<sub>SS</sub> = DV<sub>SS</sub> = 0V)

Parameter	Symbol	Pin	Condition	Value			Unit	Remarks
				Min	Typ	Max		
Output H voltage	V <sub>OH2</sub>	Normaland High Current outputs	4.5V ≤ (D)V <sub>CC</sub> ≤ 5.5V I <sub>OH</sub> = -2mA	(D)V <sub>CC</sub> - 0.5	-	-	V	Driving strength set to 2mA
			3.0V ≤ (D)V <sub>CC</sub> < 4.5V I <sub>OH</sub> = -1.6mA					
	V <sub>OH5</sub>	Normaland High Current outputs	4.5V ≤ (D)V <sub>CC</sub> ≤ 5.5V I <sub>OH</sub> = -5mA	(D)V <sub>CC</sub> - 0.5	-	-	V	Driving strength set to 5mA
			3.0V ≤ (D)V <sub>CC</sub> < 4.5V I <sub>OH</sub> = -3mA					
V <sub>OH30</sub>	High current outputs	4.5V ≤ DV <sub>CC</sub> ≤ 5.5V I <sub>OH</sub> = -30mA	DV <sub>CC</sub> - 0.5	-	-	V	Driving strength set to 30mA	
		3.0V ≤ DV <sub>CC</sub> < 4.5V I <sub>OH</sub> = -20mA						
V <sub>OH3</sub>	3mA outputs	4.5V ≤ V <sub>CC</sub> ≤ 5.5V I <sub>OH</sub> = -3mA	V <sub>CC</sub> - 0.5	-	-	V		
		3.0V ≤ V <sub>CC</sub> < 4.5V I <sub>OH</sub> = -2mA						
Output L voltage	V <sub>OL2</sub>	Normaland High Current outputs	4.5V ≤ (D)V <sub>CC</sub> ≤ 5.5V I <sub>OL</sub> = +2mA	-	-	0.4	V	Driving strength set to 2mA
			3.0V ≤ (D)V <sub>CC</sub> < 4.5V I <sub>OL</sub> = +1.6mA					
	V <sub>OL5</sub>	Normaland High Current outputs	4.5V ≤ (D)V <sub>CC</sub> ≤ 5.5V I <sub>OL</sub> = +5mA	-	-	0.4	V	Driving strength set to 5mA
			3.0V ≤ (D)V <sub>CC</sub> < 4.5V I <sub>OL</sub> = +3mA					
V <sub>OL30</sub>	High current outputs	4.5V ≤ DV <sub>CC</sub> ≤ 5.5V I <sub>OL</sub> = +30mA	-	-	0.5	V	Driving strength set to 30mA	
		3.0V ≤ DV <sub>CC</sub> < 4.5V I <sub>OL</sub> = +20mA						
V <sub>OL3</sub>	3mA outputs	3.0V ≤ V <sub>CC</sub> ≤ 5.5V I <sub>OL</sub> = +3mA	-	-	0.4	V		
Input leak current	I <sub>IL</sub>	Pnn_m	V <sub>SS</sub> < V <sub>I</sub> < V <sub>CC</sub> AV <sub>SS</sub> , AV <sub>RL</sub> < V <sub>I</sub> < AV <sub>CC</sub> , AV <sub>RH</sub>	-1	-	+1	μA	Single port pin

# MB96370 Series

( $T_A = -40^{\circ}\text{C}$  to  $125^{\circ}\text{C}$ ,  $V_{CC} = AV_{CC} = 3.0\text{V}$  to  $5.5\text{V}$ ,  $DV_{CC} = 3.0\text{V}$  to  $5.5\text{V}$ ,  $V_{SS} = AV_{SS} = DV_{SS} = 0\text{V}$ )

Parameter	Symbol	Pin	Condition	Value			Unit	Remarks
				Min	Typ	Max		
Total LCD leak current	$\Sigma I_{LCD} $	all SEG/COM pins	$V_{CC} = 5.0\text{V}$	-	0.5	10	$\mu\text{A}$	Maximum leakage current of all LCD pins
Internal LCD divide resistance	$R_{LCD}$	Between V3 and $V_{SS}$	$V_{CC} = 5.0\text{V}$	25	40	65	$\text{k}\Omega$	
Pull-up resistance	$R_{UP}$	Pnn_m, RSTX	$V_{CC} = 3.3\text{V} \pm 10\%$	40	100	160	$\text{k}\Omega$	
			$V_{CC} = 5.0\text{V} \pm 10\%$	25	50	100	$\text{k}\Omega$	

Note: Input/output voltages of high current ports depend on  $DV_{CC}$ , of other ports on  $V_{CC}$ .

(T<sub>A</sub> = -40°C to 125°C, V<sub>CC</sub> = AV<sub>CC</sub> = 3.0V to 5.5V, DV<sub>CC</sub> = 3.0V to 5.5V, V<sub>SS</sub> = AV<sub>SS</sub> = DV<sub>SS</sub> = 0V)

Parameter	Symbol	Condition (at T <sub>A</sub> )		Value			Remarks
				Typ	Max	Unit	
Power supply current in Run modes*	I <sub>CCPLL</sub>	PLL Run mode with CLKS1/2 = 48MHz, CLKB = CLKP1/2 = 24MHz	+25°C	38	46	mA	CLKRC and CLKSC stopped. Core voltage at 1.9V
			+125°C	39	49		0 Flash/ROM wait states
		PLL Run mode with CLKS1/2 = 80MHz, CLKB = CLKP1 = 40MHz, CLKP2 = 20MHz	+25°C	48	60	mA	CLKRC and CLKSC stopped. Core voltage at 1.9V
			+125°C	49	63		1 Flash/ROM wait state
	I <sub>CCMAIN</sub>	Main Run mode with CLKS1/2 = CLKB = CLKP1/2 = 4MHz	+25°C	4.8	6	mA	CLKPLL, CLKSC and CLKRC stopped
			+125°C	5.4	8.5		1 Flash/ROM wait state
	I <sub>CCRCH</sub>	RC Run mode with CLKS1/2 = CLKB = CLKP1/2 = 2MHz	+25°C	2.9	4	mA	CLKMC, CLKPLL and CLKSC stopped
			+125°C	3.5	6.5		1 Flash/ROM wait state
	I <sub>CCRCL</sub>	RC Run mode with CLKS1/2 = CLKB = CLKP1/2 = 100kHz, SMCR:LPMS = 0	+25°C	0.4	0.6	mA	CLKMC, CLKPLL and CLKSC stopped. Voltage regulator in high power mode
			+125°C	0.9	2.9		1 Flash/ROM wait state
		RC Run mode with CLKS1/2 = CLKB = CLKP1/2 = 100kHz, SMCR:LPMS = 1	+25°C	0.15	0.25	mA	CLKMC, CLKPLL and CLKSC stopped. Voltage regulator in low power mode, no Flash programming/erasing allowed.
			+125°C	0.65	2.6		1 Flash/ROM wait state
I <sub>CCSUB</sub>	Sub Run mode with CLKS1/2 = CLKB = CLKP1/2 = 32kHz	+25°C	0.1	0.2	mA	CLKMC, CLKPLL and CLKRC stopped, no Flash programming/erasing allowed.	
		+125°C	0.6	2.4		1 Flash/ROM wait state	

# MB96370 Series

(T<sub>A</sub> = -40°C to 125°C, V<sub>CC</sub> = AV<sub>CC</sub> = 3.0V to 5.5V, DV<sub>CC</sub> = 3.0V to 5.5V, V<sub>SS</sub> = AV<sub>SS</sub> = DV<sub>SS</sub> = 0V)

Parameter	Symbol	Condition (at T <sub>A</sub> )	Value			Remarks		
			Typ	Max	Unit			
Power supply current in Sleep modes*	I <sub>CCSPLL</sub>	PLL Sleep mode with CLKS1/2 = 48MHz, CLKP1/2 = 24MHz	+25°C	11	13	mA	CLKRC and CLKSC stopped. Core voltage at 1.9V	
			+125°C	11.7	15.5			
		PLL Sleep mode with CLKS1/2 = 80MHz, CLKP1 = 40MHz, CLKP2 = 20MHz	+25°C	14	17	mA		CLKRC and CLKSC stopped. Core voltage at 1.9V
			+125°C	14.8	19.5			
	I <sub>CCSMAIN</sub>	Main Sleep mode with CLKS1/2 = CLKP1/2 = 4MHz	+25°C	1.6	2	mA	CLKPLL, CLKSC and CLKRC stopped	
			+125°C	2.1	4.2			
	I <sub>CCSRCH</sub>	RC Sleep mode with CLKS1/2 = CLKP1/2 = 2MHz	+25°C	0.9	1.4	mA	CLKMC, CLKPLL and CLKSC stopped	
			+125°C	1.5	3.5			
	I <sub>CCSRCL</sub>	RC Sleep mode with CLKS1/2 = CLKP1/2 = 100kHz, SMCR:LPMSS = 0	+25°C	0.3	0.5	mA	CLKMC, CLKPLL and CLKSC stopped. Voltage regulator in high power mode	
			+125°C	0.8	2.8			
		RC Sleep mode with CLKS1/2 = CLKP1/2 = 100kHz, SMCR:LPMSS = 1	+25°C	0.06	0.15	mA	CLKMC, CLKPLL and CLKSC stopped. Voltage regulator in low power mode	
			+125°C	0.56	2.4			
I <sub>CCSSUB</sub>	Sub Sleep mode with CLKS1/2 = CLKP1/2 = 32kHz	+25°C	0.04	0.12	mA	CLKMC, CLKPLL and CLKRC stopped		
		+125°C	0.54	2.3				



(T<sub>A</sub> = -40°C to 125°C, V<sub>CC</sub> = AV<sub>CC</sub> = 3.0V to 5.5V, DV<sub>CC</sub> = 3.0V to 5.5V, V<sub>SS</sub> = AV<sub>SS</sub> = DV<sub>SS</sub> = 0V)

Parameter	Symbol	Condition (at T <sub>A</sub> )	Value			Remarks	
			Typ	Max	Unit		
Power supply current in Timer modes*	I <sub>CCTPLL</sub>	PLL Timer mode with CLKMC = 4MHz, CLK-PLL = 48MHz	+25°C	1.6	2	mA	CLKRC and CLKSC stopped. Core voltage at 1.9V
			+125°C	2.1	4.2		
	I <sub>CCTMAIN</sub>	Main Timer mode with CLKMC = 4MHz, SMCR:LPMSS = 0	+25°C	0.35	0.5	mA	CLKPLL, CLKRC and CLKSC stopped. Voltage regulator in high power mode
			+125°C	0.85	2.7		
		Main Timer mode with CLKMC = 4MHz, SMCR:LPMSS = 1	+25°C	0.1	0.15	mA	CLKPLL, CLKRC and CLKSC stopped. Voltage regulator in low power mode
			+125°C	0.6	2.3		
	I <sub>CCTRCH</sub>	RC Timer mode with CLKRC = 2MHz, SMCR:LPMSS = 0	+25°C	0.35	0.5	mA	CLKMC, CLKPLL and CLKSC stopped. Voltage regulator in high power mode
			+125°C	0.85	2.7		
		RC Timer mode with CLKRC = 2MHz, SMCR:LPMSS = 1	+25°C	0.1	0.15	mA	CLKMC, CLKPLL and CLKSC stopped. Voltage regulator in low power mode
			+125°C	0.6	2.3		
	I <sub>CCTRCL</sub>	RC Timer mode with CLKRC = 100kHz, SMCR:LPMSS = 0	+25°C	0.3	0.45	mA	CLKMC, CLKPLL and CLKSC stopped. Voltage regulator in high power mode
			+125°C	0.8	2.6		
		RC Timer mode with CLKRC = 100kHz, SMCR:LPMSS = 1	+25°C	0.05	0.1	mA	CLKMC, CLKPLL and CLKSC stopped. Voltage regulator in low power mode
			+125°C	0.55	2.2		
I <sub>CCTSUB</sub>	Sub Timer mode with CLKSC = 32kHz	+25°C	0.03	0.1	mA	CLKMC, CLKPLL and CLKRC stopped	
		+125°C	0.53	2.2			

# MB96370 Series

( $T_A = -40^{\circ}\text{C}$  to  $125^{\circ}\text{C}$ ,  $V_{CC} = AV_{CC} = 3.0\text{V}$  to  $5.5\text{V}$ ,  $DV_{CC} = 3.0\text{V}$  to  $5.5\text{V}$ ,  $V_{SS} = AV_{SS} = DV_{SS} = 0\text{V}$ )

Parameter	Symbol	Condition (at $T_A$ )		Value			Remarks	
				Typ	Max	Unit		
Stop Mode	$I_{CCH}$	VR CR:LPMB[2:0] = 110 <sub>B</sub>	+25°C	0.02	0.08	mA	Core voltage at 1.8V	
			+125°C	0.52	2.2			
		VR CR:LPMB[2:0] = 000 <sub>B</sub>	+25°C	0.015	0.06	mA		Core voltage at 1.2V
			+125°C	0.4	1.65			
Power supply current for active Low Voltage detector	$I_{CCLVD}$	Low voltage detector enabled (RCR:LVDE = 1)	+25°C	90	140	$\mu\text{A}$	This current must be added to all Power supply currents above	
			+125°C	100	150			
Clock modulator current	$I_{CCCLOMO}$	Clock modulator enabled (CMCR:PDX = 1)	-	3	4.5	mA	Must be added to all current above	
Flash Write/Erase current	$I_{CCFLASH}$	Current for one Flash module	-	15	40	mA	Must be added to all current above	
Input capacitance	$C_{IN}$	-	-	15	30	pF	High current outputs	
Input capacitance	$C_{IN}$	-	-	5	15	pF	Other than C, AV <sub>CC</sub> , AV <sub>SS</sub> , AVRH, AVRL, V <sub>CC</sub> , V <sub>SS</sub> , DV <sub>CC</sub> , DV <sub>SS</sub> , High current outputs	

\* The power supply current is measured with a 4MHz external clock connected to the Main oscillator and a 32kHz external clock connected to the Sub oscillator. See chapter "Standby mode and voltage regulator control circuit" of the Hardware Manual for further details about voltage regulator control.

## 4. AC Characteristics

### Source Clock timing

( $T_A = -40^{\circ}\text{C}$  to  $125^{\circ}\text{C}$ ,  $V_{CC} = AV_{CC} = 3.0\text{V}$  to  $5.5\text{V}$ ,  $DV_{CC} = 3.0\text{V}$  to  $5.5\text{V}$ ,  $V_{SS} = AV_{SS} = DV_{SS} = 0\text{V}$ )

Parameter	Symbol	Pin	Value			Unit	Remarks
			Min	Typ	Max		
Clock frequency	$f_c$	X0, X1	3	-	16	MHz	When using a crystal oscillator, PLL off
			0	-	16	MHz	When using an opposite phase external clock, PLL off
			3.5	-	16	MHz	When using a crystal oscillator or opposite phase external clock, PLL on
Clock frequency	$f_{FCI}$	X0	0	-	56	MHz	When using a single phase external clock in "Fast Clock Input mode", PLL off
			3.5	-	56	MHz	When using a single phase external clock in "Fast Clock Input mode", PLL on
Clock frequency	$f_{CL}$	X0A, X1A	32	32.768	100	kHz	When using an oscillation circuit
			0	-	100	kHz	When using an opposite phase external clock
		X0A	0	-	50	kHz	When using a single phase external clock
Clock frequency	$f_{CR}$	-	50	100	200	kHz	When using slow frequency of RC oscillator
			1	2	4	MHz	When using fast frequency of RC oscillator
PLL Clock frequency	$f_{CLKVCO}$	-	64	-	200	MHz	Permitted VCO output frequency of PLL (CLKVCO)
PLL Phase Jitter	$T_{PSKEW}$	-	-	-	$\pm 5$	ns	For CLKMC (PLL input clock) $\geq 4\text{MHz}$
Input clock pulse width	$P_{WH}, P_{WL}$	X0,X1	8	-	-	ns	Duty ratio is about 30% to 70%
Input clock pulse width	$P_{WHL}, P_{WLL}$	X0A,X1A	5	-	-	$\mu\text{s}$	

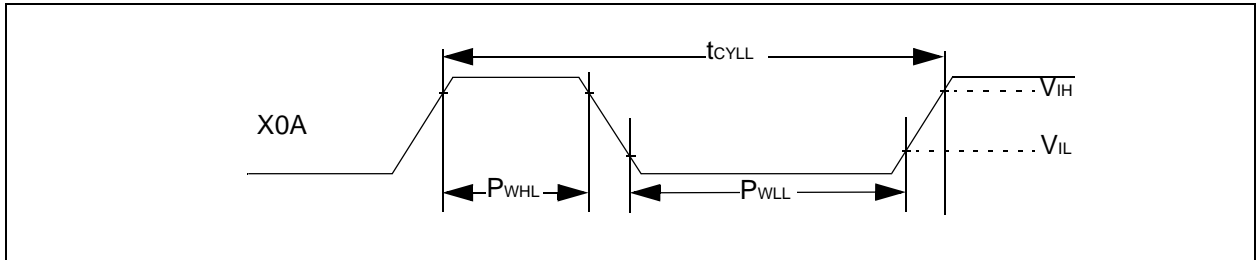
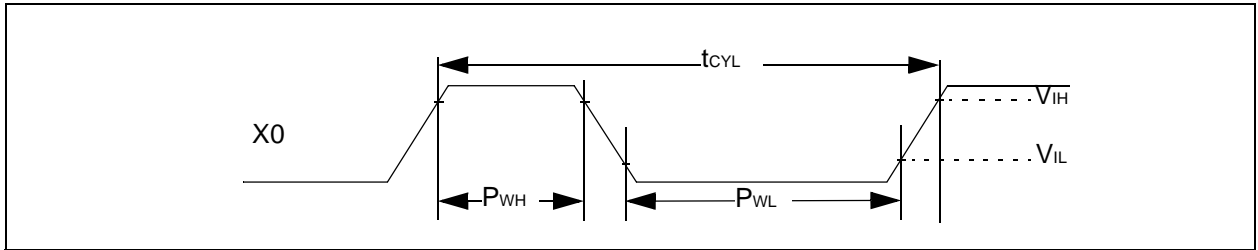

## Internal Clock timing

( $T_A = -40^{\circ}\text{C}$  to  $125^{\circ}\text{C}$ ,  $V_{CC} = AV_{CC} = 3.0\text{V}$  to  $5.5\text{V}$ ,  $DV_{CC} = 3.0\text{V}$  to  $5.5\text{V}$ ,  $V_{SS} = AV_{SS} = DV_{SS} = 0\text{V}$ )

Parameter	Symbol	Core Voltage Settings				Unit	Remarks
		1.8V		1.9V			
		Min	Max	Min	Max		
Internal System clock frequency (CLKS1 and CLKS2)	$f_{\text{CLKS1}}, f_{\text{CLKS2}}$	0	92	0	96	MHz	Others than below
		0	72	0	80	MHz	MB96F378/ MB96F379
Internal CPU clock frequency (CLKB), internal peripheral clock frequency (CLKP1)	$f_{\text{CLKB}}, f_{\text{CLKP1}}$	0	52	0	56	MHz	Others than below
		0	36	0	40	MHz	MB96F378/ MB96F379
Internal peripheral clock frequency (CLKP2)	$f_{\text{CLKP2}}$	0	28	0	32	MHz	

# MB96370 Series

## External Reset timing

( $T_A = -40^{\circ}\text{C}$  to  $125^{\circ}\text{C}$ ,  $V_{CC} = AV_{CC} = 3.0\text{V}$  to  $5.5\text{V}$ ,  $DV_{CC} = 3.0\text{V}$  to  $5.5\text{V}$ ,  $V_{SS} = AV_{SS} = DV_{SS} = 0\text{V}$ )

Parameter	Symbol	Pin	Value			Unit	Remarks
			Min	Typ	Max		
Reset input time	$t_{RSTL}$	RSTX	500	-	-	ns	

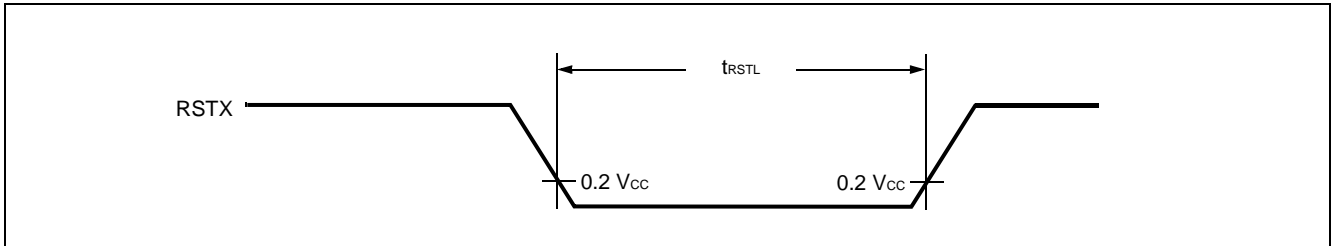

## Power On Reset timing

( $T_A = -40^{\circ}\text{C}$  to  $125^{\circ}\text{C}$ ,  $V_{CC} = AV_{CC} = 3.0\text{V}$  to  $5.5\text{V}$ ,  $DV_{CC} = 3.0\text{V}$  to  $5.5\text{V}$ ,  $V_{SS} = AV_{SS} = DV_{SS} = 0\text{V}$ )

Parameter	Symbol	Pin	Value			Unit	Remarks
			Min	Typ	Max		
Power on rise time	$t_R$	V <sub>CC</sub>	0.05	-	30	ms	
Power off time	$t_{OFF}$	V <sub>CC</sub>	1	-	-	ms	

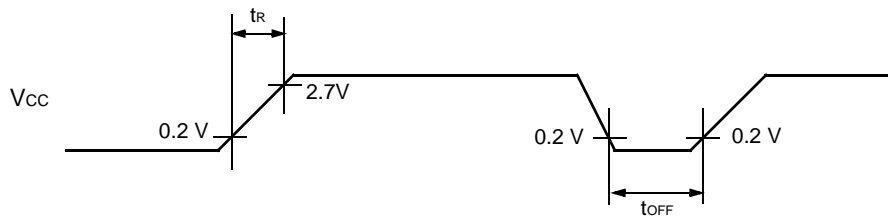

If the power supply is changed too rapidly, a power-on reset may occur.  
We recommend a smooth startup by restraining voltages when changing the power supply voltage during operation, as shown in the figure below.



# MB96370 Series

## External Input timing

( $T_A = -40^{\circ}\text{C}$  to  $125^{\circ}\text{C}$ ,  $V_{CC} = AV_{CC} = 3.0\text{V}$  to  $5.5\text{V}$ ,  $DV_{CC} = 3.0\text{V}$  to  $5.5\text{V}$ ,  $V_{SS} = AV_{SS} = DV_{SS} = 0\text{V}$ )

Parameter	Symbol	Pin	Condition	Value		Unit	Used Pin input function
				Min	Max		
Input pulse width	$t_{INH}$ $t_{INL}$	INTn(_R)	—	200	—	ns	External Interrupt
		NMI(_R)					NMI
		Pnn_m		$2 \cdot t_{CLKP1} + 200$ ( $t_{CLKP1} = 1/f_{CLKP1}$ )	—	ns	General Purpose IO
		TINn(_R)					Reload Timer
		TTGn(_R)					PPG Trigger input
		ADTG(_R)					AD Converter Trigger
		FRCKn(_R)					Free Running Timer external clock
		INn(_R)					Input Capture

Note : Relocated Resource Inputs have same characteristics

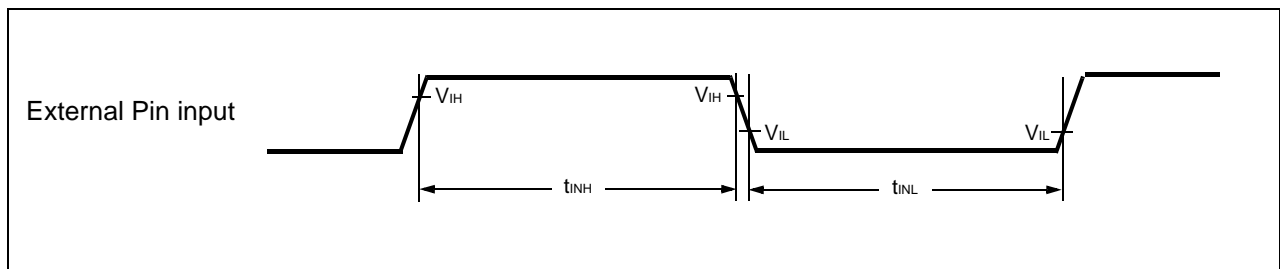



## Slew Rate High Current Outputs

( $T_A = -40^{\circ}\text{C}$  to  $125^{\circ}\text{C}$ ,  $V_{CC} = AV_{CC} = 3.0\text{V}$  to  $5.5\text{V}$ ,  $DV_{CC} = 3.0\text{V}$  to  $5.5\text{V}$ ,  $V_{SS} = AV_{SS} = DV_{SS} = 0\text{V}$ )

Parameter	Symbol	Pin	Condition	Value		Unit	Remarks
				Min	Max		
Output rise/fall time	$t_{R30}$ $t_{F30}$	I/O circuit type M	Output driving strength set to "30mA"	15	—	ns	

Note : Relocated Resource Inputs have same characteristics

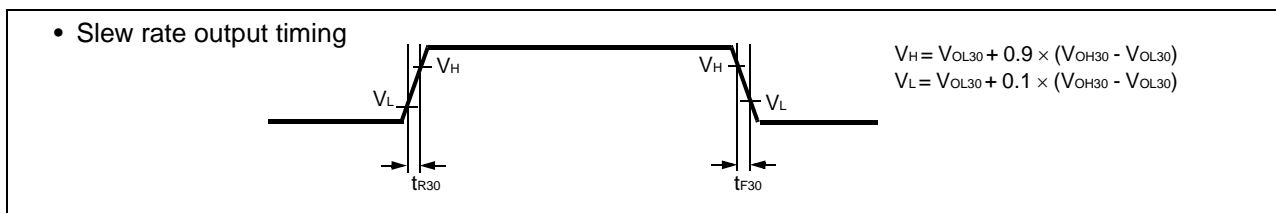

# MB96370 Series

## External Bus timing

Note: The values given below are for an I/O driving strength  $I_{Odrive} = 5mA$ . If  $I_{Odrive}$  is 2mA, all the maximum output timing described in the different tables must then be increased by 10ns.

## Basic Timing

( $T_A = -40\text{ }^{\circ}\text{C}$  to  $+125\text{ }^{\circ}\text{C}$ ,  $V_{CC} = 5.0\text{ V} \pm 10\%$ ,  $V_{SS} = 0.0\text{ V}$ ,  $I_{Odrive} = 5mA$ ,  $C_L = 50pF$ )

Parameter	Symbol	Pin	Condition	Value		Unit	Remarks
				Min	Max		
ECLK	t <sub>CYC</sub>	ECLK	—	25	—	ns	
	t <sub>CHCL</sub>			t <sub>CYC/2-5</sub>	t <sub>CYC/2+5</sub>		
	t <sub>CLCH</sub>			t <sub>CYC/2-5</sub>	t <sub>CYC/2+5</sub>		
ECLK → UBX/ LBX / CSn time	t <sub>CHCBH</sub>	CSn, UBX, LBX, ECLK	—	-20	20	ns	
	t <sub>CHCBL</sub>			-20	20		
	t <sub>CLCBH</sub>			-20	20		
	t <sub>CLCBL</sub>			-20	20		
ECLK → ALE time	t <sub>CHLH</sub>	ALE, ECLK	—	-10	10	ns	
	t <sub>CHLL</sub>			-10	10		
	t <sub>CLLH</sub>			-10	10		
	t <sub>CLLL</sub>			-10	10		
ECLK → address valid time (non-multiplexed)	t <sub>CHAV</sub>	A[23:0], ECLK	EBM:NMS=1	-15	15	ns	
	t <sub>CLAV</sub>			-15	15		
ECLK → address valid time (multiplexed)	t <sub>CHAV</sub>	A[23:16], ECLK	EBM:NMS=0	-15	15	ns	
	t <sub>CLAV</sub>			-15	15		
	t <sub>CLADV</sub>	AD[15:0], ECLK	EBM:NMS=0	-15	15	ns	
	t <sub>CHADV</sub>			-15	15		
ECLK → RDX /WRX time	t <sub>CHRWH</sub>	RDX, WRX, WRLX, WRHX, ECLK	—	-10	10	ns	
	t <sub>CHRWL</sub>			-10	10		
	t <sub>CLRWH</sub>			-10	10		
	t <sub>CLRWL</sub>			-10	10		

# MB96370 Series

( $T_A = -40\text{ }^\circ\text{C}$  to  $+125\text{ }^\circ\text{C}$ ,  $V_{CC} = 3.0$  to  $4.5\text{V}$ ,  $V_{SS} = 0.0\text{ V}$ ,  $I_{Odrive} = 5\text{mA}$ ,  $C_L = 50\text{pF}$ )

Parameter	Symbol	Pin	Condition	Value		Unit	Remarks
				Min	Max		
ECLK	t <sub>CYC</sub>	ECLK	—	30	—	ns	
	t <sub>CHCL</sub>			t <sub>CYC</sub> /2-8	t <sub>CYC</sub> /2+8		
	t <sub>CLCH</sub>			t <sub>CYC</sub> /2-8	t <sub>CYC</sub> /2+8		
ECLK → UBX/ LBX / CSn time	t <sub>CHCBH</sub>	CSn, UBX, LBX, ECLK	—	-25	25	ns	
	t <sub>CHCBL</sub>			-25	25		
	t <sub>CLCBH</sub>			-25	25		
	t <sub>CLCBL</sub>			-25	25		
ECLK → ALE time	t <sub>CHLH</sub>	ALE, ECLK	—	-15	15	ns	
	t <sub>CHLL</sub>			-15	15		
	t <sub>CLLH</sub>			-15	15		
	t <sub>CLLL</sub>			-15	15		
ECLK → address valid time (non-multiplexed)	t <sub>CHAV</sub>	A[23:0], ECLK	EBM:NMS=1	-20	20	ns	
	t <sub>CLAV</sub>			-20	20		
ECLK → address valid time (multiplexed)	t <sub>CHAV</sub>	A[23:16], ECLK	EBM:NMS=0	-20	20	ns	
	t <sub>CLAV</sub>			-20	20		
	t <sub>CLADV</sub>	AD[15:0], ECLK	EBM:NMS=0	-20	20	ns	
	t <sub>CHADV</sub>			-20	20		
ECLK → RDX /WRX time	t <sub>CHRWH</sub>	RDX, WRX, WRLX, WRHX, ECLK	—	-15	15	ns	
	t <sub>CHRWL</sub>			-15	15		
	t <sub>CLRWH</sub>			-15	15		
	t <sub>CLRWL</sub>			-15	15		

# MB96370 Series

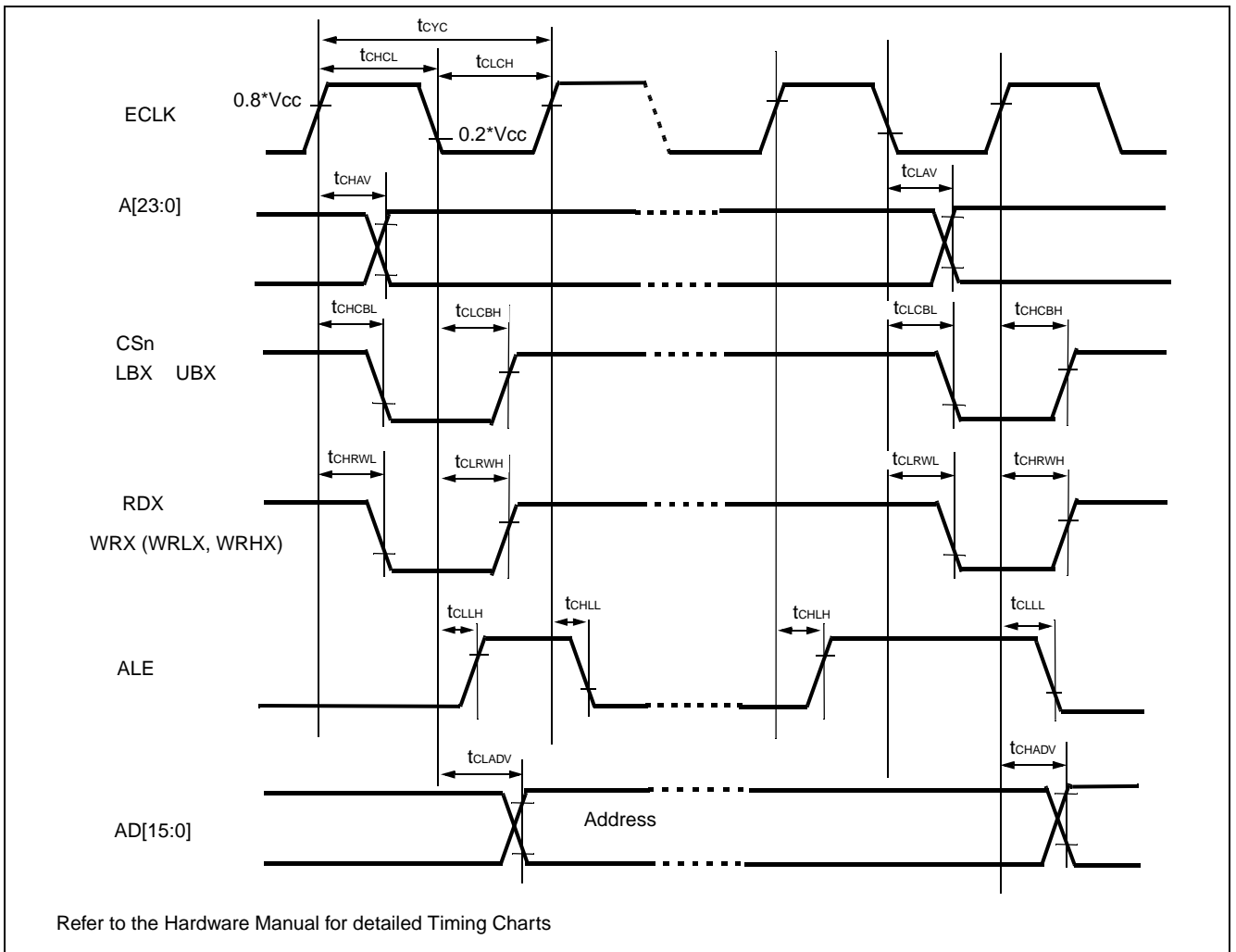

## Bus Timing (Read)

(T<sub>A</sub> = -40 °C to +125 °C, V<sub>CC</sub> = 5.0 V ± 10%, V<sub>SS</sub> = 0.0 V, I<sub>Odrive</sub> = 5mA, C<sub>L</sub> = 50pF)

Parameter	Symbol	Pin	Conditions	Value		Unit	Remarks
				Min	Max		
ALE pulse width (multiplexed)	t <sub>LHLL</sub>	ALE	EACL:STS=0 and EACL:ACE=0	t <sub>cyc</sub> /2 - 5	—	ns	EBM:NMS = 0
			EACL:STS=1	t <sub>cyc</sub> - 5	—		
			EACL:STS=0 and EACL:ACE=1	3t <sub>cyc</sub> /2 - 5	—		
Valid address ⇒ ALE ↓ time (multiplexed)	t <sub>AVLL</sub>	ALE, A[23:16],	EACL:STS=0 and EACL:ACE=0	t <sub>cyc</sub> - 15	—	ns	
			EACL:STS=1 and EACL:ACE=0	3t <sub>cyc</sub> /2 - 15	—		
			EACL:STS=0 and EACL:ACE=1	2t <sub>cyc</sub> - 15	—		
			EACL:STS=1 and EACL:ACE=1	5t <sub>cyc</sub> /2 - 15	—		
	t <sub>ADVLL</sub>	ALE, AD[15:0]	EACL:STS=0 and EACL:ACE=0	t <sub>cyc</sub> /2 - 15	—	ns	
			EACL:STS=1 and EACL:ACE=0	t <sub>cyc</sub> - 15	—		
			EACL:STS=0 and EACL:ACE=1	3t <sub>cyc</sub> /2 - 15	—		
			EACL:STS=1 and EACL:ACE=1	2t <sub>cyc</sub> - 15	—		
ALE ↓ ⇒ Address valid time (multiplexed)	t <sub>LLAX</sub>	ALE, AD[15:0]	EACL:STS=0	t <sub>cyc</sub> /2 - 15	—	ns	
			EACL:STS=1	-15	—		
Valid address ⇒ RDX ↓ time (non-multiplexed)	t <sub>AVRL</sub>	RDX, A[23:0]	EBM:NMS= 1	t <sub>cyc</sub> /2 - 15	—	ns	
Valid address ⇒ RDX ↓ time (multiplexed)	t <sub>AVRL</sub>	RDX, A[23:16]	EACL:ACE=0 EBM:NMS=0	3t <sub>cyc</sub> /2 - 15	—	ns	
			EACL:ACE=1 EBM:NMS=0	5t <sub>cyc</sub> /2 - 15	—		
	t <sub>ADVRL</sub>	RDX, AD[15:0]	EACL:ACE=0 EBM:NMS=0	t <sub>cyc</sub> - 15	—	ns	
			EACL:ACE=1 EBM:NMS=0	2t <sub>cyc</sub> - 15	—		
Valid address ⇒ Valid data input (non-multiplexed)	t <sub>AVDV</sub>	A[23:0], AD[15:0]	EBM:NMS= 1	—	2t <sub>cyc</sub> - 55	ns	w/o cycle extension

# MB96370 Series

( $T_A = -40\text{ }^\circ\text{C}$  to  $+125\text{ }^\circ\text{C}$ ,  $V_{CC} = 5.0\text{ V} \pm 10\%$ ,  $V_{SS} = 0.0\text{ V}$ ,  $I_{Odrive} = 5\text{mA}$ ,  $C_L = 50\text{pF}$ )

Parameter	Symbol	Pin	Conditions	Value		Unit	Remarks
				Min	Max		
Valid address ⇒ Valid data input (multiplexed)	$t_{AVDV}$	A[23:16], AD[15:0]	EACL:ACE=0 EBM:NMS=0	—	$3t_{CYC} - 55$	ns	w/o cycle extension
			EACL:ACE=1 EBM:NMS=0	—	$4t_{CYC} - 55$		
	$t_{ADV DV}$	AD[15:0]	EACL:ACE=0 EBM:NMS=0	—	$5t_{CYC}/2 - 55$	ns	w/o cycle extension
			EACL:ACE=1 EBM:NMS=0	—	$7t_{CYC}/2 - 55$		
RDX pulse width	$t_{RLRH}$	RDX	—	$3 t_{CYC}/2 - 5$	—	ns	w/o cycle extension
RDX ↓ ⇒ Valid data input	$t_{RLDV}$	RDX, AD[15:0]	—	—	$3 t_{CYC}/2 - 50$	ns	w/o cycle extension
RDX ↑ ⇒ Data hold time	$t_{RHDX}$	RDX, AD[15:0]	—	0	—	ns	
Address valid ⇒ Data hold time	$t_{AXDX}$	A[23:0], AD[15:0]	—	0	—	ns	
RDX ↑ ⇒ ALE ↑ time	$t_{RHLH}$	RDX, ALE	EACL:STS=1 and EACL:ACE=1	$3t_{CYC}/2 - 10$	—	ns	
			other ECL:STS, EACL:ACE setting	$t_{CYC}/2 - 10$	—		
Valid address ⇒ ECLK ↑ time	$t_{AVCH}$	A[23:0], ECLK	—	$t_{CYC} - 15$	—	ns	
	$t_{ADVCH}$	AD[15:0], ECLK		$t_{CYC}/2 - 15$	—		
RDX ↓ ⇒ ECLK ↑ time	$t_{RLCH}$	RDX, ECLK	—	$t_{CYC}/2 - 10$	—	ns	
ALE ↓ ⇒ RDX ↓ time	$t_{LLRL}$	ALE, RDX	EACL:STS=0	$t_{CYC}/2 - 10$	—	ns	
			EACL:STS=1	- 10	—		
ECLK↑ ⇒ Valid data input	$t_{CHDV}$	AD[15:0], ECLK	—	—	$t_{CYC} - 50$	ns	

( $T_A = -40\text{ }^\circ\text{C}$  to  $+125\text{ }^\circ\text{C}$ ,  $V_{CC} = 3.0$  to  $4.5\text{V}$ ,  $V_{SS} = 0.0\text{V}$ ,  $I_{Odrive} = 5\text{mA}$ ,  $C_L = 50\text{pF}$ )

Parameter	Symbol	Pin	Conditions	Value		Unit	Remarks
				Min	Max		
ALE pulse width (multiplexed)	$t_{LHLL}$	ALE	EACL:STS=0 and EACL:ACE=0	$t_{cyc}/2 - 8$	—	ns	EBM:NMS = 0
			EACL:STS=1	$t_{cyc} - 8$	—		
			EACL:STS=0 and EACL:ACE=1	$3t_{cyc}/2 - 8$	—		
Valid address ⇒ ALE ↓ time (multiplexed)	$t_{AVLL}$	ALE, A[23:16],	EACL:STS=0 and EACL:ACE=0	$t_{cyc} - 20$	—	ns	
			EACL:STS=1 and EACL:ACE=0	$3t_{cyc}/2 - 20$	—		
			EACL:STS=0 and EACL:ACE=1	$2t_{cyc} - 20$	—		
			EACL:STS=1 and EACL:ACE=1	$5t_{cyc}/2 - 20$	—		
	$t_{ADVLL}$	ALE, AD[15:0]	EACL:STS=0 and EACL:ACE=0	$t_{cyc}/2 - 20$	—	ns	
			EACL:STS=1 and EACL:ACE=0	$t_{cyc} - 20$	—		
			EACL:STS=0 and EACL:ACE=1	$3t_{cyc}/2 - 20$	—		
			EACL:STS=1 and EACL:ACE=1	$2t_{cyc} - 20$	—		
ALE ↓ ⇒ Address valid time (multiplexed)	$t_{LLAX}$	ALE, AD[15:0]	EACL:STS=0	$t_{cyc}/2 - 20$	—	ns	
			EACL:STS=1	-20	—		
Valid address ⇒ RDX ↓ time (non-multiplexed)	$t_{AVRL}$	RDX, A[23:0]	EBM:NMS= 1	$t_{cyc}/2 - 20$	—	ns	
Valid address ⇒ RDX ↓ time (multiplexed)	$t_{AVRL}$	RDX, A[23:16]	EACL:ACE=0 EBM:NMS=0	$3t_{cyc}/2 - 20$	—	ns	
			EACL:ACE=1 EBM:NMS=0	$5t_{cyc}/2 - 20$	—		
	$t_{ADVRL}$	RDX, AD[15:0]	EACL:ACE=0 EBM:NMS=0	$t_{cyc} - 20$	—	ns	
			EACL:ACE=1 EBM:NMS=0	$2t_{cyc} - 20$	—		
Valid address ⇒ Valid data input (non-multiplexed)	$t_{AVDV}$	A[23:0], AD[15:0]	EBM:NMS= 1	—	$2t_{cyc} - 60$	ns	w/o cycle extension

# MB96370 Series

( $T_A = -40\text{ }^\circ\text{C}$  to  $+125\text{ }^\circ\text{C}$ ,  $V_{CC} = 3.0$  to  $4.5\text{V}$ ,  $V_{SS} = 0.0\text{V}$ ,  $I_{Odrive} = 5\text{mA}$ ,  $C_L = 50\text{pF}$ )

Parameter	Symbol	Pin	Conditions	Value		Unit	Remarks
				Min	Max		
Valid address ⇒ Valid data input (multiplexed)	$t_{AVDV}$	A[23:16], AD[15:0]	EACL:ACE=0 EBM:NMS=0	—	$3t_{CYC} - 60$	ns	w/o cycle extension
			EACL:ACE=1 EBM:NMS=0	—	$4t_{CYC} - 60$		
	$t_{ADVDV}$	AD[15:0]	EACL:ACE=0 EBM:NMS=0	—	$5t_{CYC}/2 - 60$	ns	w/o cycle extension
			EACL:ACE=1 EBM:NMS=0	—	$7t_{CYC}/2 - 60$		
RDX pulse width	$t_{RLRH}$	RDX	—	$3t_{CYC}/2 - 8$	—	ns	w/o cycle extension
RDX ↓ ⇒ Valid data input	$t_{RLDV}$	RDX, AD[15:0]	—	—	$3t_{CYC}/2 - 55$	ns	w/o cycle extension
RDX ↑ ⇒ Data hold time	$t_{RHDX}$	RDX, AD[15:0]	—	0	—	ns	
Address valid ⇒ Data hold time	$t_{AXDX}$	A[23:0]	—	0	—	ns	
RDX ↑ ⇒ ALE ↑ time	$t_{RHLH}$	RDX, ALE	EACL:STS=1 and EACL:ACE=1	$3t_{CYC}/2 - 15$	—	ns	
			other ECL:STS, EACL:ACE setting	$t_{CYC}/2 - 15$	—		
Valid address ⇒ ECLK ↑ time	$t_{AVCH}$	A[23:0], ECLK	—	$t_{CYC} - 20$	—	ns	
	$t_{ADVCH}$	AD[15:0], ECLK		$t_{CYC}/2 - 20$	—		
RDX ↓ ⇒ ECLK ↑ time	$t_{RLCH}$	RDX, ECLK	—	$t_{CYC}/2 - 15$	—	ns	
ALE ↓ ⇒ RDX ↓ time	$t_{LLRL}$	ALE, RDX	EACL:STS=0	$t_{CYC}/2 - 15$	—	ns	
			EACL:STS=1	- 15	—		
ECLK↑ ⇒ Valid data input	$t_{CHDV}$	AD[15:0], ECLK	—	—	$t_{CYC} - 55$	ns	



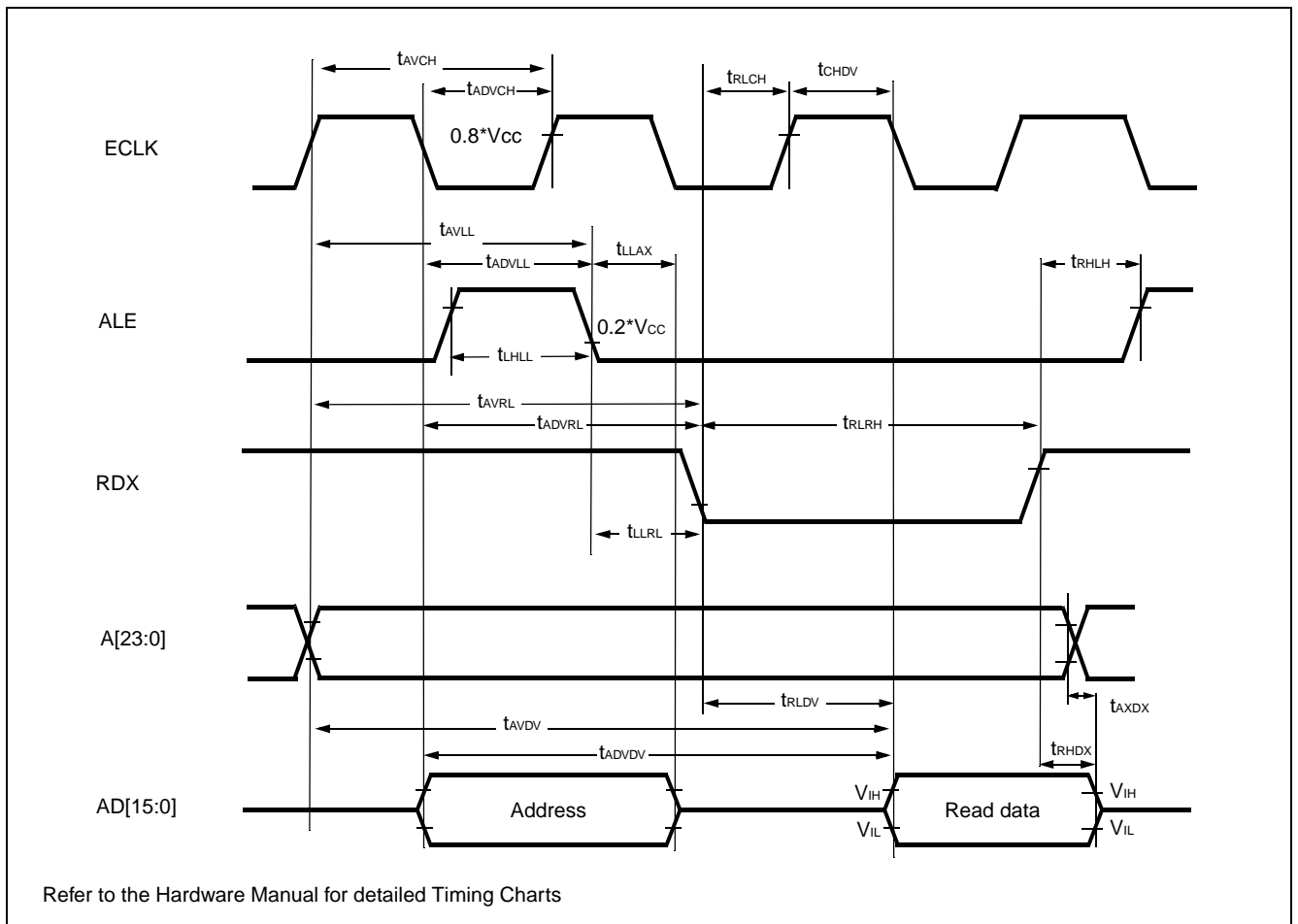

## Bus Timing (Write)

( $T_A = -40\text{ }^\circ\text{C}$  to  $+125\text{ }^\circ\text{C}$ ,  $V_{CC} = 5.0\text{ V} \pm 10\%$ ,  $V_{SS} = 0.0\text{ V}$ ,  $I_{Odrive} = 5\text{ mA}$ ,  $C_L = 50\text{ pF}$ )

Parameter	Symbol	Pin	Condition	Value		Unit	Remarks
				Min	Max		
Valid address ⇒ WRX ↓ time (non-multiplexed)	$t_{AVWL}$	WRX, WRLX, WRHX, A[23:0]	EACL:STS=0 EBM:NMS=1	$t_{cyc}/2 - 15$	—	ns	
			EACL:STS=1 EBM:NMS=1	$t_{cyc} - 15$	—		
Valid address ⇒ WRX ↓ time (multiplexed)	$t_{AVWL}$	WRX, WRLX, WRHX, A[23:16]	EACL:ACE=0 EBM:NMS=0	$3t_{cyc}/2 - 15$	—	ns	
			EACL:ACE=1 EBM:NMS=0	$5t_{cyc}/2 - 15$	—		
	$t_{ADVWL}$	WRX, WRLX, WRHX, AD[15:0]	EACL:ACE=0 EBM:NMS=0	$t_{cyc} - 15$	—	ns	
			EACL:ACE=1 EBM:NMS=0	$2t_{cyc} - 15$	—		
WRX pulse width	$t_{WLWH}$	WRX, WRXL, WRHX	—	$t_{cyc} - 5$	—	ns	w/o cycle extension

# MB96370 Series

( $T_A = -40\text{ }^\circ\text{C}$  to  $+125\text{ }^\circ\text{C}$ ,  $V_{CC} = 5.0\text{ V} \pm 10\%$ ,  $V_{SS} = 0.0\text{ V}$ ,  $I_{Odrive} = 5\text{mA}$ ,  $C_L = 50\text{pF}$ )

Parameter	Symbol	Pin	Condition	Value		Unit	Remarks
				Min	Max		
Valid data output ⇒ WRX ↑ time	$t_{DVWH}$	WRX, WRLX, WRHX, AD[15:0]	—	$t_{cyc} - 20$	—	ns	w/o cycle extension
WRX ↑ ⇒ Data hold time	$t_{WHDX}$	WRX, WRLX, WRHX, AD[15:0]	—	$t_{cyc}/2 - 15$	—	ns	
WRX ↑ ⇒ Address valid time (non-multiplexed)	$t_{WHAX}$	WRX, WRLX, WRHX, A[23:0]	EACL:STS=1 EBM:NMS=1	- 15	—	ns	
			EACL:STS=0 EBM:NMS=1	$t_{cyc}/2 - 15$	—	ns	
WRX ↑ ⇒ Address valid time (multiplexed)	$t_{WHAX}$	WRX, WRLX, WRHX, A[23:16]	EBM:NMS=0	$t_{cyc}/2 - 15$	—	ns	
WRX ↑ ⇒ ALE ↑ time (multiplexed)	$t_{WHLH}$	WRX, WRLX, WRHX, ALE	EBM:ACE=1 and EACL:STS=1	$2t_{cyc} - 10$	—	ns	EBM:NMS=0
			other EBM:ACE and EACL:STS setting	$t_{cyc} - 10$	—		
WRX ↓ ⇒ ECLK ↑ time	$t_{WLCH}$	WRX, WRLX, WRHX, ECLK	—	$t_{cyc}/2 - 10$	—	ns	
CSn ⇒ WRX time (non-multiplexed)	$t_{CSLWL}$	WRX, WRLX, WRHX, CSn	EACL:STS=0 EBM:NMS=1	—	$t_{cyc}/2 - 15$	ns	
			EACL:STS=1 EBM:NMS=1	—	$t_{cyc} - 15$		
CSn ⇒ WRX time (multiplexed)	$t_{CSLWL}$	WRX, WRLX, WRHX, CSn	EACL:ACE=0 EBM:NMS=0	—	$3t_{cyc}/2 - 15$	ns	
			EACL:ACE=1 EBM:NMS=0	—	$5t_{cyc}/2 - 15$		
WRX ⇒ CSn time (non-multiplexed)	$t_{WHCSH}$	WRX, WRLX, WRHX, CSn	EACL:STS=1 EBM:NMS=1	- 15	—	ns	
			EACL:STS=0 EBM:NMS=1	$t_{cyc}/2 - 15$	—	ns	
WRX ⇒ CSn time (multiplexed)	$t_{WHCSH}$	WRX, WRLX, WRHX, CSn	EBM:NMS=0	$t_{cyc}/2 - 15$	—	ns	

( $T_A = -40\text{ }^\circ\text{C}$  to  $+125\text{ }^\circ\text{C}$ ,  $V_{CC} = 3.0$  to  $4.5\text{V}$ ,  $V_{SS} = 0.0\text{ V}$ ,  $I_{Odrive} = 5\text{mA}$ ,  $C_L = 50\text{pF}$ )

Parameter	Symbol	Pin	Condition	Value		Unit	Remarks
				Min	Max		
Valid address ⇒ WRX ↓ time (non-multiplexed)	$t_{AVWL}$	WRX, WRLX, WRHX, A[23:0]	EACL:STS=0 EBM:NMS=1	$t_{cyc}/2 - 20$	—	ns	
			EACL:STS=1 EBM:NMS=1	$t_{cyc} - 20$	—		

# MB96370 Series

(T<sub>A</sub> = -40 °C to +125 °C, V<sub>CC</sub> = 3.0 to 4.5V, V<sub>SS</sub> = 0.0 V, I<sub>Odrive</sub> = 5mA, C<sub>L</sub> = 50pF)

Parameter	Symbol	Pin	Condition	Value		Unit	Remarks
				Min	Max		
Valid address ⇒ WRX ↓ time (multiplexed)	t <sub>AVWL</sub>	WRX, WRLX, WRHX, A[23:16]	EACL:ACE=0 EBM:NMS=0	3t <sub>cyc</sub> /2 - 20	—	ns	
			EACL:ACE=1 EBM:NMS=0	5t <sub>cyc</sub> /2 - 20	—		
	t <sub>ADVWL</sub>	WRX, WRLX, WRHX, AD[15:0]	EACL:ACE=0 EBM:NMS=0	t <sub>cyc</sub> - 20	—	ns	
			EACL:ACE=1 EBM:NMS=0	2t <sub>cyc</sub> - 20	—		
WRX pulse width	t <sub>WLWH</sub>	WRX, WRXL, WRHX	—	t <sub>cyc</sub> - 8	—	ns	w/o cycle extension
Valid data output ⇒ WRX ↑ time	t <sub>DVWH</sub>	WRX, WRLX, WRHX, AD[15:0]	—	t <sub>cyc</sub> - 25	—	ns	w/o cycle extension
WRX ↑ ⇒ Data hold time	t <sub>WHDX</sub>	WRX, WRLX, WRHX, AD[15:0]	—	t <sub>cyc</sub> /2 - 20	—	ns	
WRX ↑ ⇒ Address valid time (non-multiplexed)	t <sub>WHAX</sub>	WRX, WRLX, WRHX, A[23:0]	EACL:STS=1 EBM:NMS=1	- 20	—	ns	
			EACL:STS=0 EBM:NMS=1	t <sub>cyc</sub> /2 - 20	—	ns	
WRX ↑ ⇒ Address valid time (multiplexed)	t <sub>WHAX</sub>	WRX, WRLX, WRHX, A[23:16]	EBM:NMS=0	t <sub>cyc</sub> /2 - 20	—	ns	
WRX ↑ ⇒ ALE ↑ time (multiplexed)	t <sub>WHLH</sub>	WRX, WRLX, WRHX, ALE	EBM:ACE=1 and EACL:STS=1	2t <sub>cyc</sub> - 15	—	ns	EBM:NMS=0
			other EBM:ACE and EACL:STS setting	t <sub>cyc</sub> - 15	—		
WRX ↓ ⇒ ECLK ↑ time	t <sub>WLCH</sub>	WRX, WRLX, WRHX, ECLK	—	t <sub>cyc</sub> /2 - 15	—	ns	
CSn ⇒ WRX time (non-multiplexed)	t <sub>CSLWL</sub>	WRX, WRLX, WRHX, CSn	EACL:STS=0 EBM:NMS=1	—	t <sub>cyc</sub> /2 - 20	ns	
			EACL:STS=1 EBM:NMS=1	—	t <sub>cyc</sub> - 20		
CSn ⇒ WRX time (multiplexed)	t <sub>CSLWL</sub>	WRX, WRLX, WRHX, CSn	EACL:ACE=0 EBM:NMS=0	—	3t <sub>cyc</sub> /2 - 20	ns	
			EACL:ACE=1 EBM:NMS=0	—	5t <sub>cyc</sub> /2 - 20		
WRX ⇒ CSn time (non-multiplexed)	t <sub>WHCSH</sub>	WRX, WRLX, WRHX, CSn	EACL:STS=1 EBM:NMS=1	- 20	—	ns	
			EACL:STS=0 EBM:NMS=1	t <sub>cyc</sub> /2 - 20	—	ns	
WRX ⇒ CSn time (multiplexed)	t <sub>WHCSH</sub>	WRX, WRLX, WRHX, CSn	EBM:NMS=0	t <sub>cyc</sub> /2 - 20	—	ns	

# MB96370 Series

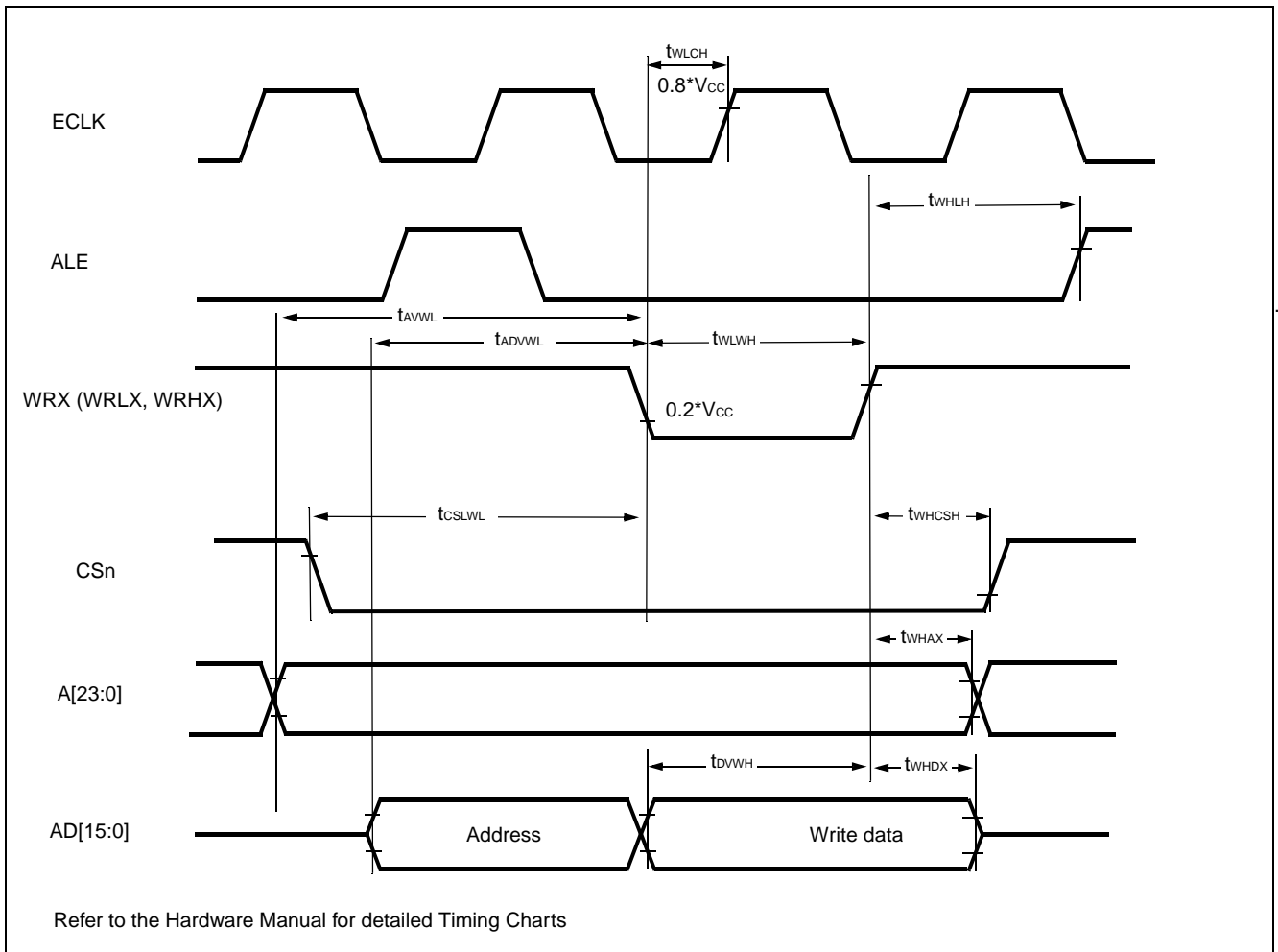

## Ready Input Timing

( $T_A = -40\text{ }^\circ\text{C}$  to  $+125\text{ }^\circ\text{C}$ ,  $V_{CC} = 5.0\text{ V} \pm 10\%$ ,  $V_{SS} = 0.0\text{ V}$ ,  $I_{Odrive} = 5\text{ mA}$ ,  $C_L = 50\text{ pF}$ )

Parameter	Symbol	Pin	Test Condition	Rated Value		Units	Remarks
				Min	Max		
RDY setup time	$t_{RYHS}$	RDY	—	35	—	ns	
RDY hold time	$t_{RYHH}$	RDY		0	—	ns	

( $T_A = -40\text{ }^\circ\text{C}$  to  $+125\text{ }^\circ\text{C}$ ,  $V_{CC} = 3.0$  to  $4.5\text{ V}$ ,  $V_{SS} = 0.0\text{ V}$ ,  $I_{Odrive} = 5\text{ mA}$ ,  $C_L = 50\text{ pF}$ )

Parameter	Symbol	Pin	Test Condition	Rated Value		Units	Remarks
				Min	Max		
RDY setup time	$t_{RYHS}$	RDY	—	45	—	ns	
RDY hold time	$t_{RYHH}$	RDY		0	—	ns	

Note : If the RDY setup time is insufficient, use the auto-ready function.

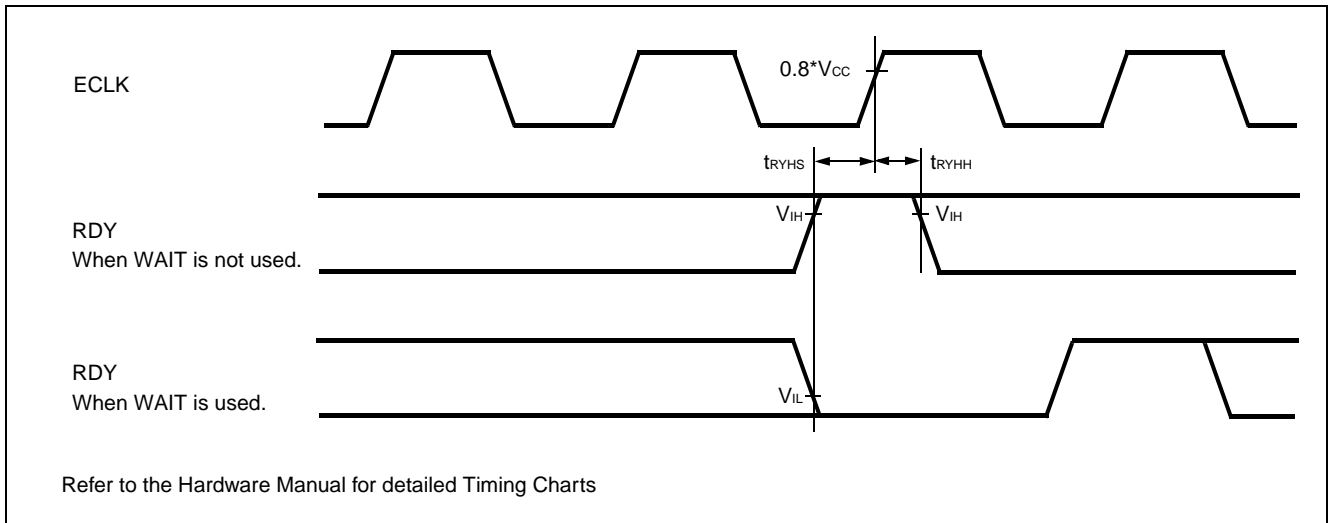

## Hold Timing

( $T_A = -40\text{ }^\circ\text{C}$  to  $+125\text{ }^\circ\text{C}$ ,  $V_{CC} = 5.0\text{ V} \pm 10\%$ ,  $V_{SS} = 0.0\text{ V}$ ,  $I_{Odrive} = 5\text{ mA}$ ,  $C_L = 50\text{ pF}$ )

Parameter	Symbol	Pin	Condition	Value		Units	Remarks
				Min	Max		
Pin floating $\Rightarrow$ HAKX $\downarrow$ time	$t_{XHAL}$	HAKX	—	$t_{CYC} - 20$	$t_{CYC} + 20$	ns	
HAKX $\uparrow$ time $\Rightarrow$ Pin valid time	$t_{HAHV}$	HAKX		$t_{CYC} - 20$	$t_{CYC} + 20$	ns	

( $T_A = -40\text{ }^\circ\text{C}$  to  $+125\text{ }^\circ\text{C}$ ,  $V_{CC} = 3.0$  to  $4.5\text{ V}$ ,  $V_{SS} = 0.0\text{ V}$ ,  $I_{Odrive} = 5\text{ mA}$ ,  $C_L = 50\text{ pF}$ )

Parameter	Symbol	Pin	Condition	Value		Units	Remarks
				Min	Max		
Pin floating $\Rightarrow$ HAKX $\downarrow$ time	$t_{XHAL}$	HAKX	—	$t_{CYC} - 25$	$t_{CYC} + 25$	ns	
HAKX $\uparrow$ time $\Rightarrow$ Pin valid time	$t_{HAHV}$	HAKX		$t_{CYC} - 25$	$t_{CYC} + 25$	ns	

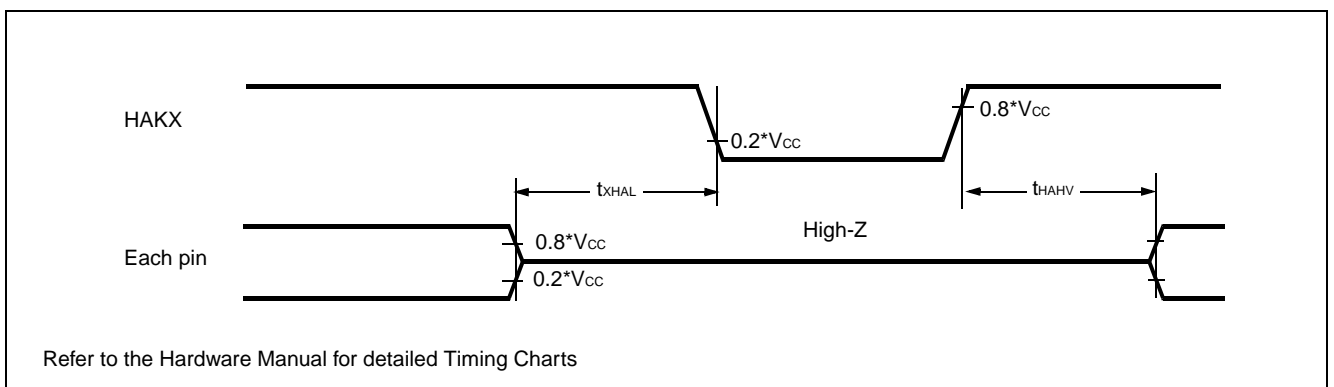

# MB96370 Series

## USART timing

WARNING: The values given below are for an I/O driving strength  $I_{Odrive} = 5mA$ . If  $I_{Odrive}$  is 2mA, all the maximum output timing described in the different tables must then be increased by 10ns.

( $T_A = -40^{\circ}C$  to  $125^{\circ}C$ ,  $V_{CC} = 3.0V$  to  $5.5V$ ,  $V_{SS} = AV_{SS} = 0V$ ,  $I_{Odrive} = 5mA$ ,  $C_L = 50pF$ )

Parameter	Symbol	Pin	Condition	$V_{CC} = AV_{CC} = 4.5V$ to $5.5V$		$V_{CC} = AV_{CC} = 3.0V$ to $4.5V$		Unit
				Min	Max	Min	Max	
Serial clock cycle time	$t_{SCYCI}$	SCKn	Internal Shift Clock Mode	$4 t_{CLKP1}$	—	$4 t_{CLKP1}$	—	ns
SCK ↓ → SOT delay time	$t_{SLOVI}$	SCKn, SOTn		-20	+20	-30	+30	ns
SOT → SCK ↑ delay time	$t_{OVSHI}$	SCKn, SOTn		$N * t_{CLKP1} - 20^{*1}$	—	$N * t_{CLKP1} - 30^{*1}$	—	ns
Valid SIN → SCK ↑	$t_{IVSHI}$	SCKn, SINn		$t_{CLKP1} + 45$	—	$t_{CLKP1} + 55$	—	ns
SCK ↑ → Valid SIN hold time	$t_{SHIXI}$	SCKn, SINn		0	—	0	—	ns
Serial clock “L” pulse width	$t_{LSHE}$	SCKn	External Shift Clock Mode	$t_{CLKP1} + 10$	—	$t_{CLKP1} + 10$	—	ns
Serial clock “H” pulse width	$t_{HSLE}$	SCKn		$t_{CLKP1} + 10$	—	$t_{CLKP1} + 10$	—	ns
SCK ↓ → SOT delay time	$t_{SLOVE}$	SCKn, SOTn		—	$2 t_{CLKP1} + 45$	—	$2 t_{CLKP1} + 55$	ns
Valid SIN → SCK ↑	$t_{IVSHE}$	SCKn, SINn		$t_{CLKP1}/2 + 10$	—	$t_{CLKP1}/2 + 10$	—	ns
SCK ↑ → Valid SIN hold time	$t_{SHIXE}$	SCKn, SINn		$t_{CLKP1} + 10$	—	$t_{CLKP1} + 10$	—	ns
SCK fall time	$t_{FE}$	SCKn		—	20	—	20	ns
SCK rise time	$t_{RE}$	SCKn		—	20	—	20	ns

Notes: • AC characteristic in CLK synchronized mode.

- $C_L$  is the load capacity value of pins when testing.
- Depending on the used machine clock frequency, the maximum possible baud rate can be limited by some parameters. These parameters are shown in “MB96300 Super series HARDWARE MANUAL”
- $t_{CLKP1}$  is the cycle time of the peripheral clock 1 (CLKP1), Unit : ns

\*1: Parameter N depends on  $t_{SCYCI}$  and can be calculated as follows:

- if  $t_{SCYCI} = 2 * k * t_{CLKP1}$ , then  $N = k$ , where  $k$  is an integer  $> 2$
- if  $t_{SCYCI} = (2 * k + 1) * t_{CLKP1}$ , then  $N = k + 1$ , where  $k$  is an integer  $> 1$

Examples:

$t_{SCYCI}$	N
$4 * t_{CLKP1}$	2
$5 * t_{CLKP1}, 6 * t_{CLKP1}$	3
$7 * t_{CLKP1}, 8 * t_{CLKP1}$	4
...	...

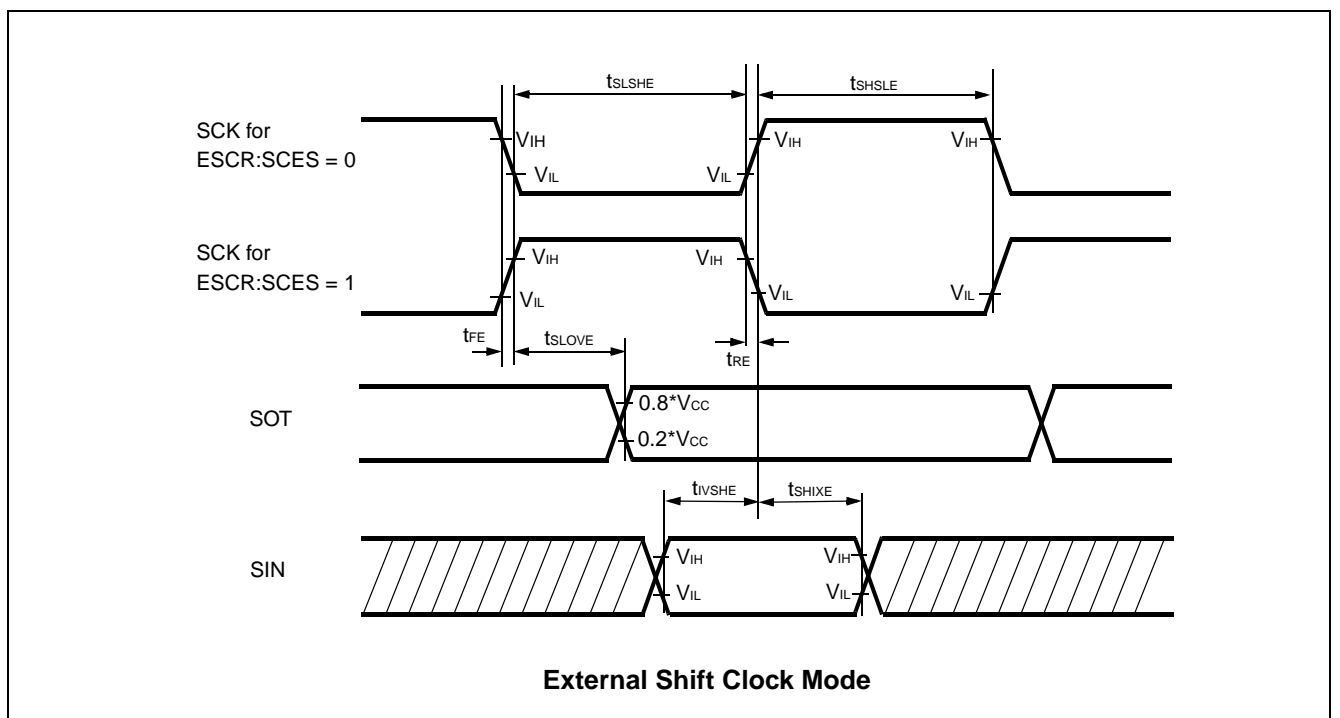
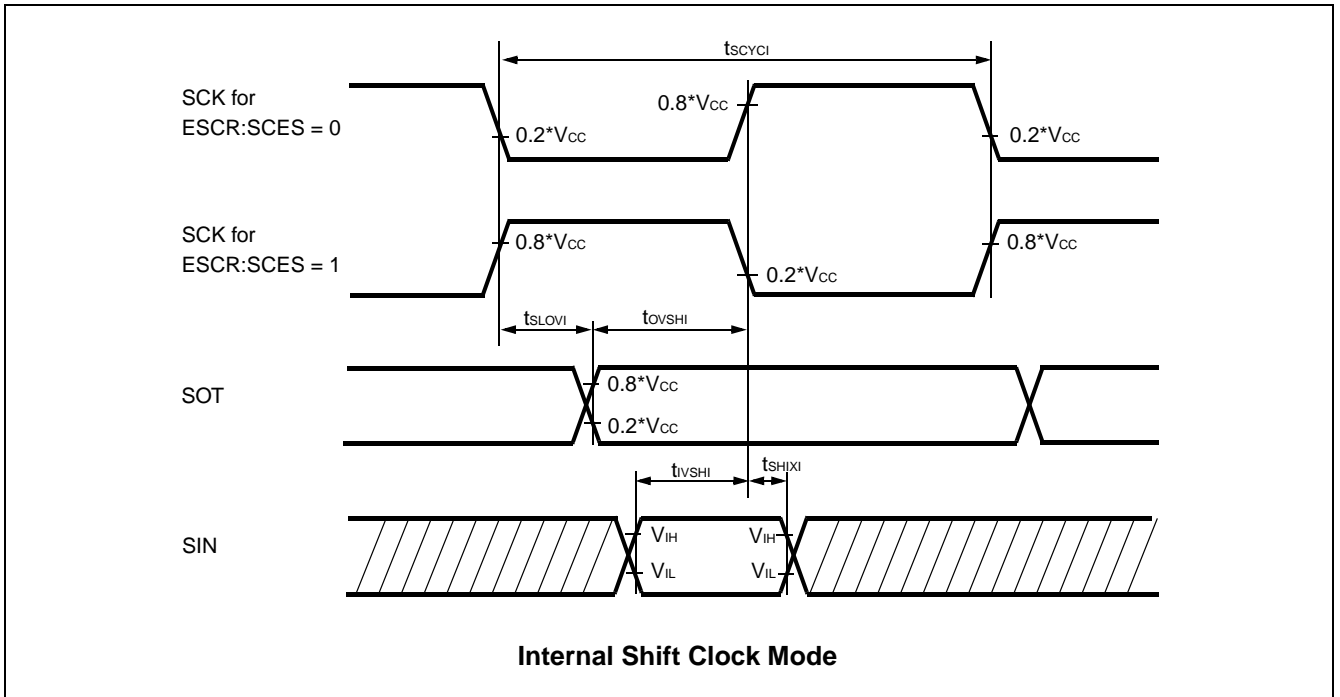

# MB96370 Series

## I<sup>2</sup>C Timing

(T<sub>A</sub> = -40°C to 125°C, V<sub>CC</sub> = AV<sub>CC</sub> = 3.0V to 5.5V, V<sub>SS</sub> = AV<sub>SS</sub> = 0V)

Parameter	Symbol	Condition	Standard-mode		Fast-mode*4		Unit
			Min	Max	Min	Max	
SCL clock frequency	f <sub>SCL</sub>	R = 1.7 kΩ, C = 50 pF*1	0	100	0	400	kHz
Hold time (repeated) START condition SDA↓→SCL↓	t <sub>HSTA</sub>		4.0	—	0.6	—	μs
"L" width of the SCL clock	t <sub>LOW</sub>		4.7	—	1.3	—	μs
"H" width of the SCL clock	t <sub>HIGH</sub>		4.0	—	0.6	—	μs
Set-up time for a repeated START condition SCL↑→SDA↓	t <sub>SUSTA</sub>		4.7	—	0.6	—	μs
Data hold time SCL↓→SDA↓↑	t <sub>HDDAT</sub>		0	3.45*2	0	0.9*3	μs
Data set-up time SDA↓↑→SCL↑	t <sub>SUDAT</sub>		250	—	100	—	ns
Set-up time for STOP condition SCL↑→SDA↑	t <sub>SUSTO</sub>		4.0	—	0.6	—	μs
Bus free time between a STOP and START condition	t <sub>BUS</sub>		4.7	—	1.3	—	μs

\*1 : R,C : Pull-up resistor and load capacitor of the SCL and SDA lines.

\*2 : The maximum t<sub>HDDAT</sub> have only to be met if the device does not stretch the "L" width (t<sub>LOW</sub>) of the SCL signal.

\*3 : A Fast-mode I<sup>2</sup>C-bus device can be used in a Standard-mode I<sup>2</sup>C-bus system, but the requirement t<sub>SUDAT</sub> ≥ 250 ns must then be met.

\*4 : For use at over 100 kHz, set the peripheral clock 1 to at least 6 MHz.

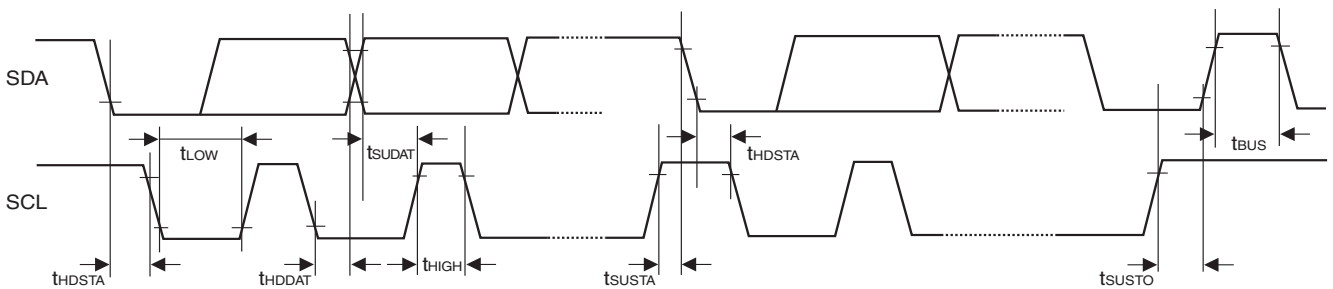



## 5. Analog Digital Converter

( $T_A = -40\text{ }^\circ\text{C}$  to  $+125\text{ }^\circ\text{C}$ ,  $3.0\text{ V} \leq \text{AVRH} - \text{AVRL}$ ,  $V_{CC} = \text{AV}_{CC} = 3.0\text{V}$  to  $5.5\text{V}$ ,  $V_{SS} = \text{AV}_{SS} = 0\text{V}$ )

Parameter	Symbol	Pin	Value			Unit	Remarks
			Min	Typ	Max		
Resolution	-	-	-	-	10	bit	
Total error	-	-	-3	-	+3	LSB	
Nonlinearity error	-	-	-2.5	-	+2.5	LSB	
Differential nonlinearity error	-	-	-1.9	-	+1.9	LSB	
Zero reading voltage	$V_{OT}$	ANn	AVRL - 1.5 LSB	AVRL + 0.5 LSB	AVRL + 2.5 LSB	V	
Full scale reading voltage	$V_{FST}$	ANn	AVRH - 3.5 LSB	AVRH - 1.5 LSB	AVRH + 0.5 LSB	V	
Compare time	-	-	1.0	-	16,500	$\mu\text{s}$	$4.5\text{V} \leq \text{AV}_{CC} \leq 5.5\text{V}$
			2.0	-	-	$\mu\text{s}$	$3.0\text{V} \leq \text{AV}_{CC} < 4.5\text{V}$
Sampling time	-	-	0.5	-	-	$\mu\text{s}$	$4.5\text{V} \leq \text{AV}_{CC} \leq 5.5\text{V}$
			1.2	-	-	$\mu\text{s}$	$3.0\text{V} \leq \text{AV}_{CC} < 4.5\text{V}$
Analog port input current	$I_{AIN}$	ANn	-3	-	+3	$\mu\text{A}$	$\text{AV}_{SS}, \text{AVRL} < V_I < \text{AV}_{CC}, \text{AVRH}$
Analog port input current	$I_{AIN}$	ANn	-1	-	+1	$\mu\text{A}$	$T_A = 25^\circ\text{C}$ , $\text{AV}_{SS}, \text{AVRL} < V_I < \text{AV}_{CC}, \text{AVRH}$
			-3	-	+3	$\mu\text{A}$	$T_A = 125^\circ\text{C}$ , $\text{AV}_{SS}, \text{AVRL} < V_I < \text{AV}_{CC}, \text{AVRH}$
Analog input voltage range	$V_{AIN}$	ANn	AVRL	-	AVRH	V	
Reference voltage range	AVRH	AVRH	0.75 $\text{AV}_{CC}$	-	$\text{AV}_{CC}$	V	
	AVRL	AVRL	$\text{AV}_{SS}$	-	0.25 $\text{AV}_{CC}$	V	
Power supply current	$I_A$	$\text{AV}_{CC}$	-	2.5	5	$\text{mA}$	A/D Converter active
	$I_{AH}$	$\text{AV}_{CC}$	-	-	5	$\mu\text{A}$	A/D Converter not operated
Reference voltage current	$I_R$	AVRH/ AVRL	-	0.7	1	$\text{mA}$	A/D Converter active
	$I_{RH}$	AVRH/ AVRL	-	-	5	$\mu\text{A}$	A/D Converter not operated
Offset between input channels	-	ANn	-	-	4	LSB	

Note: The accuracy gets worse as  $|\text{AVRH} - \text{AVRL}|$  becomes smaller.

## Definition of A/D Converter Terms

**Resolution:** Analog variation that is recognized by an A/D converter.

**Total error:** Difference between the actual value and the ideal value. The total error includes zero transition error, full-scale transition error and nonlinearity error.

**Nonlinearity error:** Deviation between a line across zero-transition line ("00 0000 0000" <--> "00 0000 0001") and full-scale transition line ("11 1111 1110" <--> "11 1111 1111") and actual conversion characteristics.

**Differential nonlinearity error:** Deviation of input voltage, which is required for changing output code by 1 LSB, from an ideal value.

**Zero reading voltage:** Input voltage which results in the minimum conversion value.

**Full scale reading voltage:** Input voltage which results in the maximum conversion value.

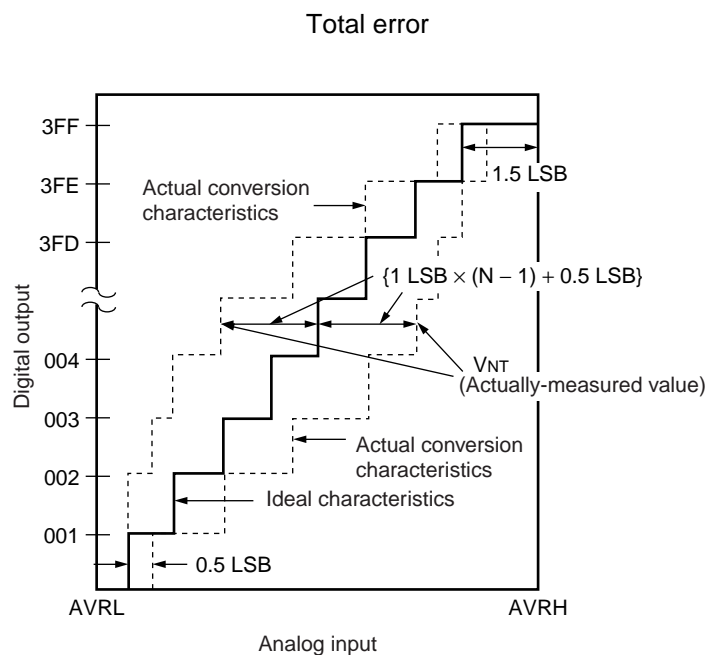

$$\text{Total error of digital output "N"} = \frac{V_{NT} - \{1 \text{ LSB} \times (N - 1) + 0.5 \text{ LSB}\}}{1 \text{ LSB}} \quad [\text{LSB}]$$

$$1 \text{ LSB} = (\text{Ideal value}) \frac{AVRH - AVRL}{1024} \quad [\text{V}]$$

N: A/D converter digital output value

$$V_{OT} (\text{Ideal value}) = AVRL + 0.5 \text{ LSB} \quad [\text{V}]$$

$$V_{FST} (\text{Ideal value}) = AVRH - 1.5 \text{ LSB} \quad [\text{V}]$$

$V_{NT}$  : A voltage at which digital output transitions from (N - 1) to N.

Nonlinearity error

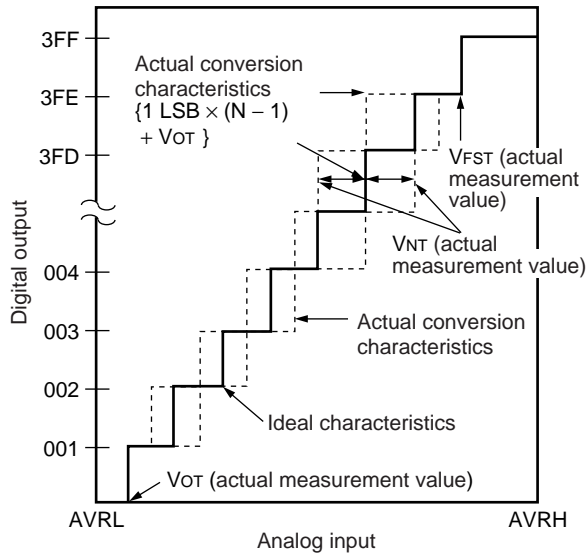

Differential nonlinearity error

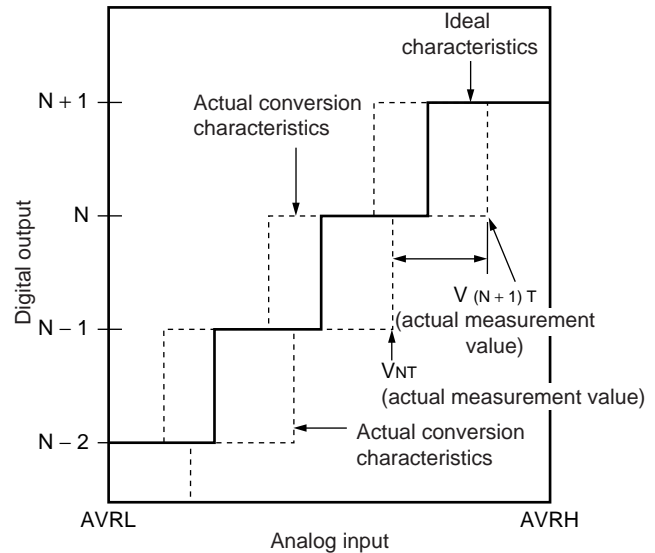

$$\text{Nonlinearity error of digital output } N = \frac{V_{NT} - \{1 \text{ LSB} \times (N - 1) + V_{OT}\}}{1 \text{ LSB}} \text{ [LSB]}$$

$$\text{Differential nonlinearity error of digital output } N = \frac{V_{(N+1)T} - V_{NT}}{1 \text{ LSB}} - 1 \text{ LSB [LSB]}$$

$$1 \text{ LSB} = \frac{V_{FST} - V_{OT}}{1022} \text{ [V]}$$

N : A/D converter digital output value

V<sub>OT</sub> : Voltage at which digital output transits from "000H" to "001H."

V<sub>FST</sub> : Voltage at which digital output transits from "3FEH" to "3FFH."

### Notes on A/D Converter Section

- About the external impedance of the analog input and the sampling time of the A/D converter (with sample and hold circuit):

If the external impedance is too high to keep sufficient sampling time, the analog voltage charged to the internal sample and hold capacitor is insufficient, adversely affecting A/D conversion precision.

- analog input circuit model:

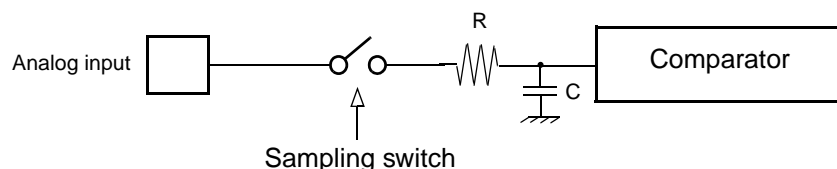

### Reference value:

- C = 8.5 pF (Max)

# MB96370 Series

To satisfy the A/D conversion precision standard, the relationship between the external impedance and minimum sampling time must be considered and then either the resistor value and operating frequency must be adjusted or the external impedance must be decreased so that the sampling time ( $T_{\text{samp}}$ ) is longer than the minimum value. Usually, this value is set to  $7\tau$ , where  $\tau = RC$ . If the external input resistance ( $R_{\text{ext}}$ ) connected to the analog input is included, the sampling time is expressed as follows:

$$T_{\text{samp}} [\text{min}] = 7 \times (R_{\text{ext}} + 2.6\text{k}\Omega) \times C \text{ for } 4.5 \leq AV_{\text{cc}} \leq 5.5$$

$$T_{\text{samp}} [\text{min}] = 7 \times (R_{\text{ext}} + 12.1\text{k}\Omega) \times C \text{ for } 3.0 \leq AV_{\text{cc}} \leq 4.5$$

If the sampling time cannot be sufficient, connect a capacitor of about 0.1  $\mu\text{F}$  to the analog input pin.

- About the error

The accuracy gets worse as  $|AV_{\text{RH}} - AV_{\text{RL}}|$  becomes smaller.

## 6. Alarm Comparator

(T<sub>A</sub> = -40 °C to +125 °C, V<sub>CC</sub> = AV<sub>CC</sub> = 3.0V - 5.5V, V<sub>SS</sub> = AV<sub>SS</sub> = 0V)

Parameter	Symbol	Pin	Value			Unit	Remarks	
			Min	Typ	Max			
Power supply current	I <sub>A5ALMF</sub>	AV <sub>CC</sub>	-	25	45	μA	Alarm comparator enabled in fast mode (one channel)	
	I <sub>A5ALMS</sub>		-	7	13	μA	Alarm comparator enabled in slow mode (one channel)	
	I <sub>A5ALMH</sub>		-	-	5	μA	Alarm comparator disabled	
ALARM pin input current	I <sub>ALIN</sub>	ALARM0, ALARM1	-1	-	+1	μA	T <sub>A</sub> = 25 °C	
			-3	-	+3	μA	T <sub>A</sub> = 125 °C	
ALARM pin input voltage range	V <sub>ALIN</sub>		0	-	AV <sub>CC</sub>	V		
External low threshold high->low transition	V <sub>EVTL(H-&gt;L)</sub>		0.36 * AV <sub>CC</sub> -0.25	0.36 * AV <sub>CC</sub> -0.1	-	V	INTREF = 0	
External low threshold low->high transition	V <sub>EVTL(L-&gt;H)</sub>		-	0.36 * AV <sub>CC</sub> +0.1	0.36 * AV <sub>CC</sub> +0.25	V		
External high threshold high->low transition	V <sub>EVTH(H-&gt;L)</sub>		0.78 * AV <sub>CC</sub> -0.25	0.78 * AV <sub>CC</sub> -0.1	-	V		
External high threshold low->high transition	V <sub>EVTH(L-&gt;H)</sub>			0.78 * AV <sub>CC</sub> +0.1	0.78 * AV <sub>CC</sub> +0.25	V		
Internal low threshold high->low transition	V <sub>IVTL(H-&gt;L)</sub>		0.9	1.1	-	V		INTREF = 1
Internal low threshold low->high transition	V <sub>IVTL(L-&gt;H)</sub>		-	1.3	1.55	V		
Internal high threshold high->low transition	V <sub>IVTH(H-&gt;L)</sub>		2.2	2.4	-	V		
Internal high threshold low->high transition	V <sub>IVTH(L-&gt;H)</sub>		-	2.6	2.85	V		
Switching hysteresis	V <sub>HYS</sub>		50	-	300	mV		
Comparison time	t <sub>COMP</sub> F	-	0.1	1	μs	CMD = 1 (fast)		
	t <sub>COMP</sub> S	-	1	10	μs	CMD = 0 (slow)		
Power-up stabilization time after enabling alarm comparator	t <sub>PD</sub>	-	1	5	ms	Threshold levels specified above are not guaranteed within this time		
Slow/Fast mode transition time	t <sub>CMD</sub>	-	100	500	μs			

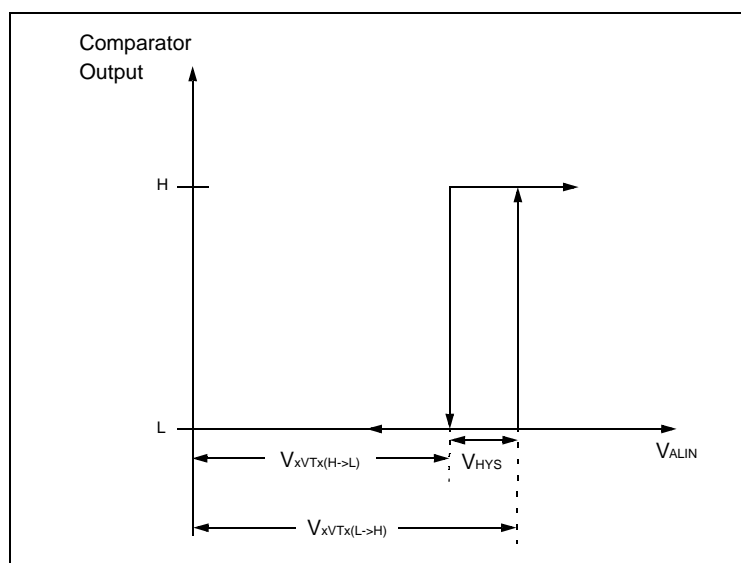

## 7. Low Voltage Detector characteristics

( $T_A = -40\text{ }^\circ\text{C}$  to  $+125\text{ }^\circ\text{C}$ ,  $V_{CC} = AV_{CC} = 3.0\text{V} - 5.5\text{V}$ ,  $V_{SS} = AV_{SS} = 0\text{V}$ )

Parameter	Symbol	Value		Unit	Remarks
		Min	Max		
Stabilization time	$T_{LVDSTAB}$	-	75	$\mu\text{s}$	After power-up or change of detection level
Level 0	$V_{DL0}$	2.7	2.9	V	CILCR:LVL[3:0]="0000"
Level 1	$V_{DL1}$	2.9	3.1	V	CILCR:LVL[3:0]="0001"
Level 2	$V_{DL2}$	3.1	3.3	V	CILCR:LVL[3:0]="0010"
Level 3	$V_{DL3}$	3.5	3.75	V	CILCR:LVL[3:0]="0011"
Level 4	$V_{DL4}$	3.6	3.85	V	CILCR:LVL[3:0]="0100"
Level 5	$V_{DL5}$	3.7	3.95	V	CILCR:LVL[3:0]="0101"
Level 6	$V_{DL6}$	3.8	4.05	V	CILCR:LVL[3:0]="0110"
Level 7	$V_{DL7}$	3.9	4.15	V	CILCR:LVL[3:0]="0111"
Level 8	$V_{DL8}$	4.0	4.25	V	CILCR:LVL[3:0]="1000"
Level 9	$V_{DL9}$	4.1	4.35	V	CILCR:LVL[3:0]="1001"
Level 10	$V_{DL10}$	not used			
Level 11	$V_{DL11}$	not used			
Level 12	$V_{DL12}$	not used			
Level 13	$V_{DL13}$	not used			
Level 14	$V_{DL14}$	not used			
Level 15	$V_{DL15}$	not used			

CILCR:LVL[3:0] are the low voltage detector level select bits of the CILCR register.

Levels 10 to 15 are not used in this device.

For correct detection, the slope of the voltage level must satisfy  $\left| \frac{dV}{dt} \right| \leq 0.004 \frac{\text{V}}{\mu\text{s}}$ .

Faster variations are regarded as noise and may not be detected.

The functional operation of the MCU is guaranteed down to the minimum low voltage detection level of  $V_{CC} = 2.7\text{V}$ . The electrical characteristics however are only valid in the specified range (usually down to 3.0V).

## Low Voltage Detector Operation

In the following figure, the occurrence of a low voltage condition is illustrated. For a detailed description of the reset and startup behavior, please refer to the corresponding hardware manual chapter.

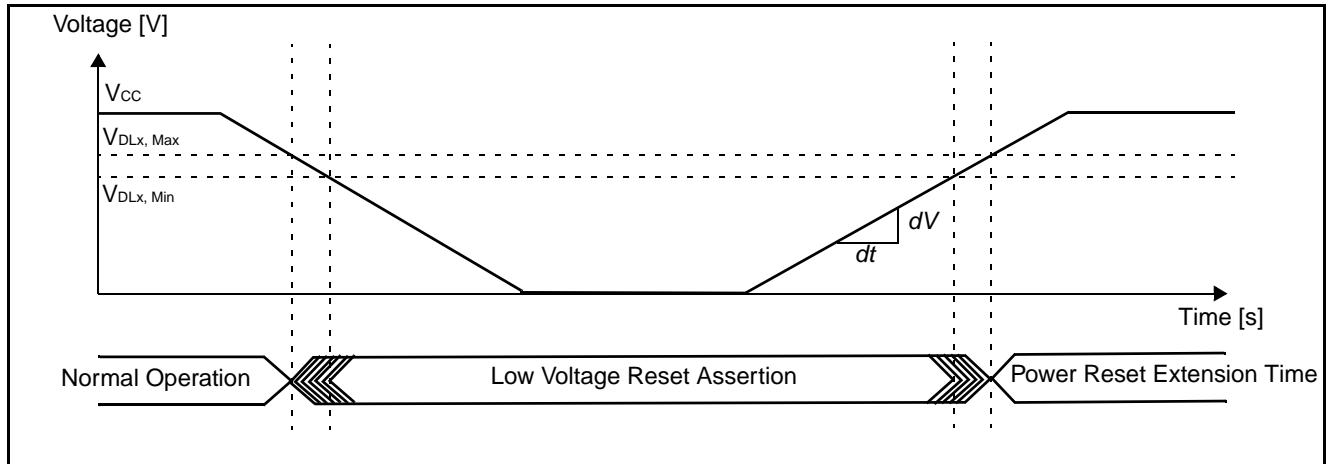



## 8. FLASH memory program/erase characteristics

( $T_A = -40^{\circ}\text{C}$  to  $105^{\circ}\text{C}$ ,  $V_{CC} = AV_{CC} = 3.0\text{V}$  to  $5.5\text{V}$ ,  $DV_{CC} = 3.0\text{V}$  to  $5.5\text{V}$ ,  $V_{SS} = AV_{SS} = DV_{SS} = 0\text{V}$ )

Parameter	Value			Unit	Remarks
	Min	Typ	Max		
Sector erase time	-	0.9	3.6	s	Without erasure pre-programming time
Chip erase time	-	n*0.9	n*3.6	s	Without erasure pre-programming time (n is the number of Flash sector of the device)
Word (16-bit width) programming time	-	23	370	us	Without overhead time for submitting write command
Program/Erase cycle	10 000	-	-	cycle	
Flash data retention time	20	-	-	year	*1

\*1: This value was converted from the results of evaluating the reliability of the technology (using Arrhenius equation to convert high temperature measurements into normalized value at  $85^{\circ}\text{C}$ )

# MB96370 Series

## ■ PACKAGE DIMENSION MB96(F)37x LQFP 144P

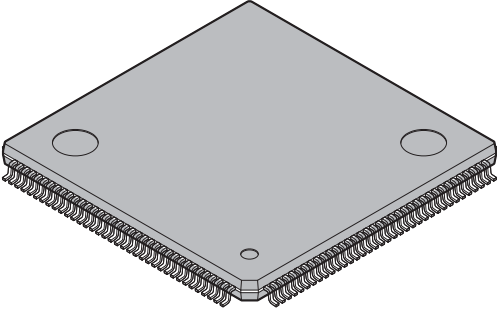
 <p>144-pin plastic LQFP</p> <p>(FPT-144P-M08)</p>	Lead pitch	0.50 mm
	Package width × package length	20.0 × 20.0 mm
	Lead shape	Gullwing
	Sealing method	Plastic mold
	Mounting height	1.70 mm MAX
	Weight	1.20g
	Code (Reference)	P-LFQFP144-20×20-0.50

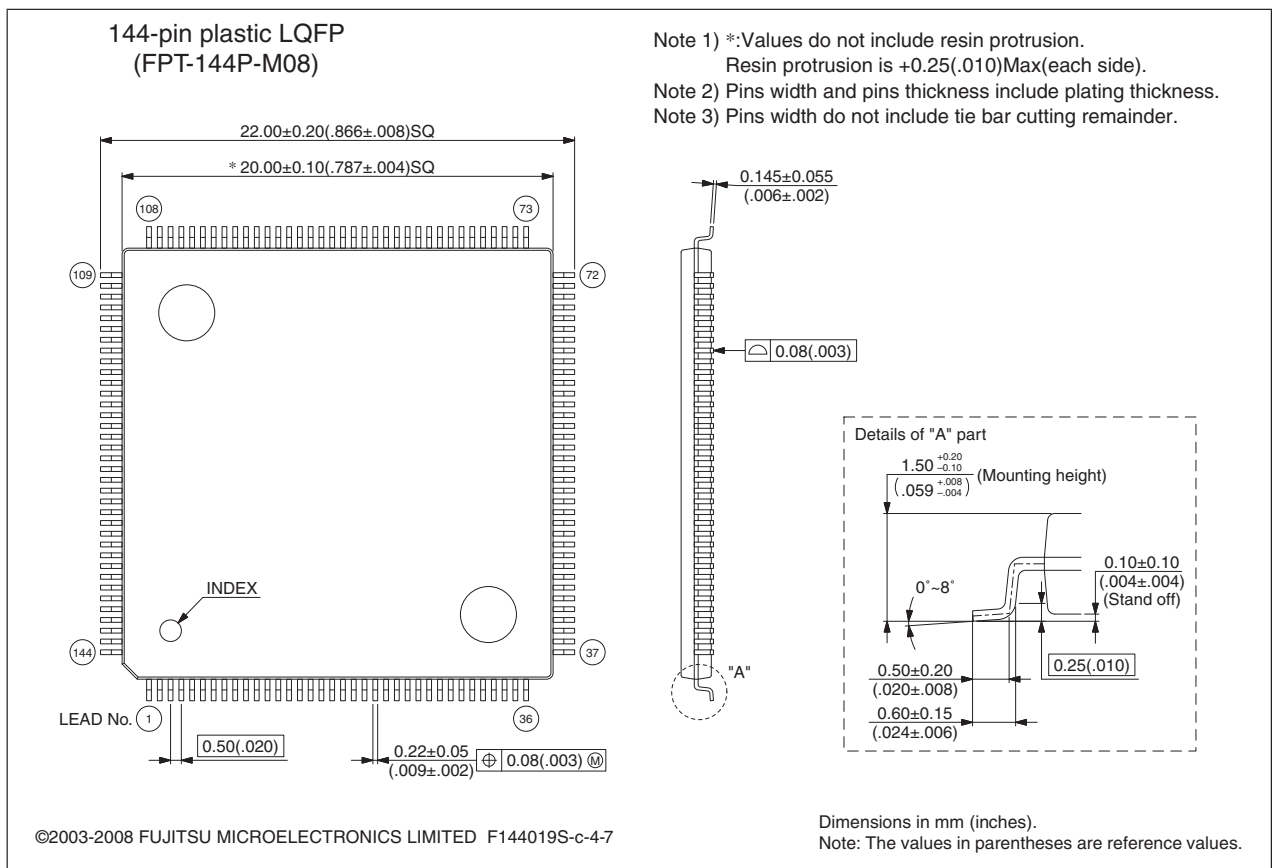

Please confirm the latest Package dimension by following URL.  
<http://edevice.fujitsu.com/package/en-search/>

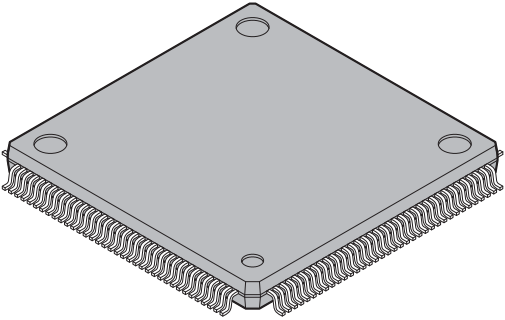
<p style="text-align: center;">144-pin plastic LQFP</p>  <p style="text-align: center;">(FPT-144P-M12)</p>	Lead pitch	0.40 mm
	Package width × package length	16.0 × 16.0 mm
	Lead shape	Gullwing
	Sealing method	Plastic mold
	Mounting height	1.70 mm MAX
	Weight	0.88 g
	Code (Reference)	P-LFQFP144-16×16-0.40

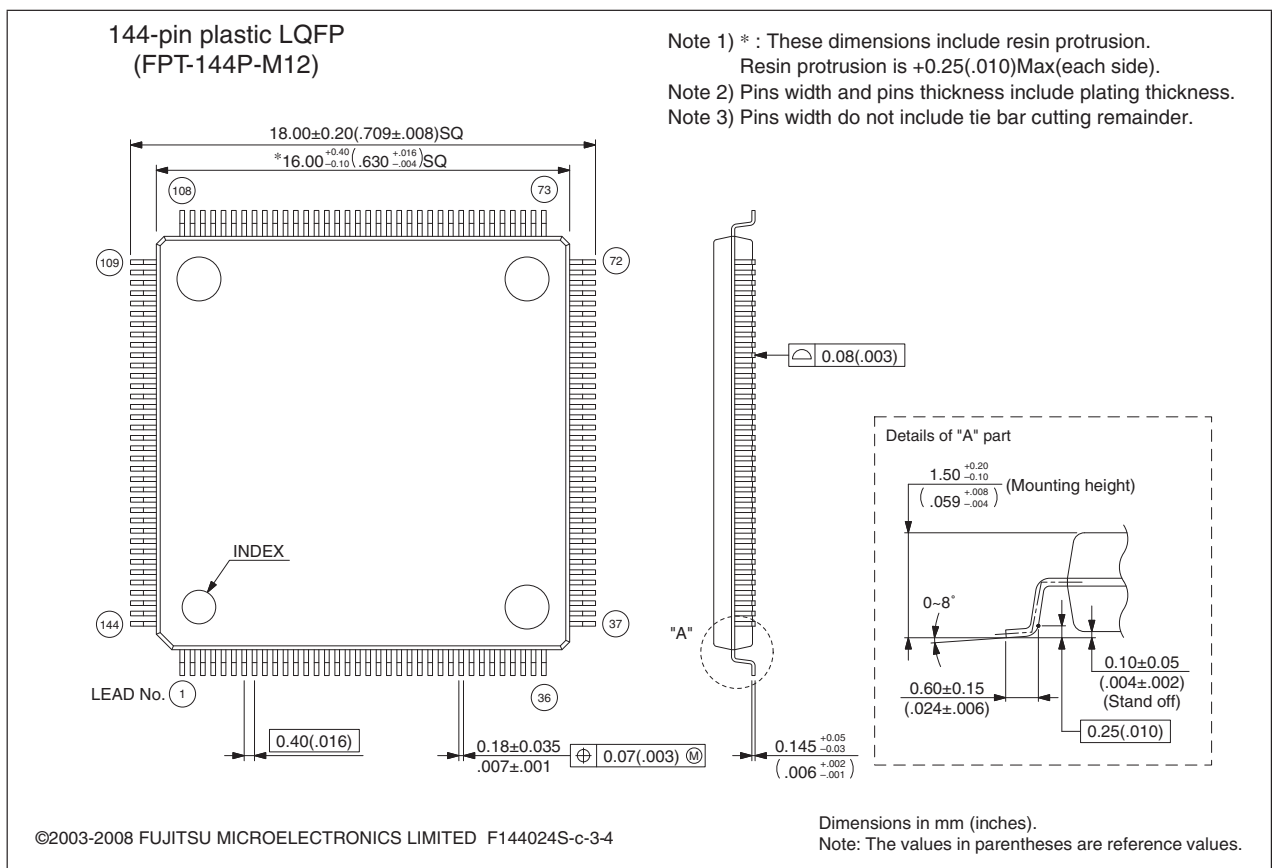

Please confirm the latest Package dimension by following URL.  
<http://edevice.fujitsu.com/package/en-search/>

# MB96370 Series

## ■ ORDERING INFORMATION

Part number	Flash/ROM	Subclock	Persistent Low Voltage Reset	Package	
MB96F378TSA PMC-GSE2 *1	Flash A (544KB) Flash B (32KB)	No	Yes	144 Pin Plastic LQFP FPT-144P-M08	
MB96F378HSA PMC-GSE2 *1			No		
MB96F378TWA PMC-GSE2 *1		Yes	Yes		
MB96F378HWA PMC-GSE2 *1			No		
MB96F378TSA PMC1-GSE2 *1		Flash A (544KB) Flash B (288KB)	No	Yes	144 Pin Plastic LQFP FPT-144P-M12
MB96F378HSA PMC1-GSE2 *1				No	
MB96F378TWA PMC1-GSE2 *1			Yes	Yes	
MB96F378HWA PMC1-GSE2 *1				No	
MB96F379YSA PMC-GSE2 *1	Flash A (544KB) Flash B (288KB)	No	Yes	144 Pin Plastic LQFP FPT-144P-M08	
MB96F379RSA PMC-GSE2 *1			No		
MB96F379YWA PMC-GSE2 *1		Yes	Yes		
MB96F379RWA PMC-GSE2 *1			No		
MB96F379YSA PMC1-GSE2 *1		Flash A (544KB) Flash B (288KB)	No	Yes	144 Pin Plastic LQFP FPT-144P-M12
MB96F379RSA PMC1-GSE2 *1				No	
MB96F379YWA PMC1-GSE2 *1			Yes	Yes	
MB96F379RWA PMC1-GSE2 *1				No	
MB96V300BRB-ES (for evaluation)	Emulated by ext. RAM	Yes	No	416 pin Plastic BGA (BGA-416P-M02)	

\*1: These devices are under development and specification is preliminary. These products under development may change its specification without notice.

## ■ REVISION HISTORY

Revision	Date	Modification
Prelim 1	2007-11-27	Creation
Prelim 2	2007-12-19	Add TTG3/TTG7 in pin assignment Some IO circuit drawings have been modified. Modification of the memory map and IO map Block diagram includes now the relocated pins Main Flash becomes Flash memory A, Satellite Flash becomes Flash memory B
Prelim 3	2008-04-14	<ul style="list-style-type: none"> <li>• Added note for devices under development</li> <li>• Maximum CPU frequency corrected to 40MHz</li> <li>• Product lineup: Product options added, reload timer for PPG added</li> <li>• Block diagram: Flash B added, CKOT*_R added, IN*_R added</li> <li>• Pin assignment: CKOT0_R added</li> <li>• Pin function description corrected (all existing pin types included)</li> <li>• Pin circuit types: Description improved</li> <li>• Memory map: common 16FX memory map included</li> <li>• External bus and RAM start/end addressed specified more precise</li> <li>• Flash sector addresses: Start/end addresses corrected</li> <li>• Serial programming interface: Note about handshaking pins improved</li> <li>• I/O map newly generated (naming style update)</li> <li>• Permitted power dissipation specified</li> <li>• Ordering information updated</li> <li>• Disclaimer added</li> <li>• ICC spec corrected (wrong conditions were specified). However specification is still preliminary, especially regarding the leakage current.</li> </ul>

# MB96370 Series

Revision	Date	Modification
Prelim 4	2009-01-09	<ul style="list-style-type: none"> <li>• Format adjusted to official Fujitsu Microelectronics datasheet standard (mainly style changes and official notes and disclaimer added)</li> <li>• specified AD converter channel offset to 4LSB</li> <li>• package code of MB96V300 corrected in ordering information</li> <li>• Internal LCD divider resistance value corrected: Typ 35kOhm -&gt; 40kOhm, Max 50kOhm -&gt; 65kOhm</li> <li>• Added voltage condition to pull-up resistance and LCD divide resistance spec</li> <li>• Lineup: Term "Data Flash" replaced by "independent 32KB Flash"</li> <li>• Ordering information: column "Satellite Flash" replaced by new column "Flash/ROM", column "Remarks" removed</li> <li>• Official package dimension drawing with additional notes added</li> <li>• Empty pages removed</li> <li>• DC values adjusted after evaluation (higher Run and Sleep mode currents, smaller standby current at high temp)</li> <li>• Alarm comparator: Power supply current max values increased, comparison time reduced, mode transition time and power-up stabilization time newly added</li> <li>• Handling devices: Notes added about Serial communication and about using ceramic resonators.</li> <li>• Feature list and AC Characteristics: 16MHz maximum frequency is valid for crystal oscillators. For resonators, maximum frequency depends on Q-factor</li> <li>• AC characteristics: PLL phase skew spec added, CLKVCO min=64MHz</li> <li>• VOL3 spec improved: spec valid for 3mA load for full Vcc range</li> <li>• C-Pin cap spec updated: 4.7uF-10uF capacitor with tolerance permitted</li> </ul>

## ■ MAIN CHANGES IN THIS EDITION

Page	Section	Change Results
97	■ ELECTRICAL CHARACTERISTICS 5. Analog Digital Converter	Changed the item for “Zero reading voltage” and “Full scale reading voltage”.

The vertical lines marked in the left side of the page show the changes.

# MB96370 Series

## FUJITSU MICROELECTRONICS LIMITED

Shinjuku Dai-Ichi Seimei Bldg., 7-1, Nishishinjuku 2-chome,  
Shinjuku-ku, Tokyo 163-0722, Japan  
Tel: +81-3-5322-3329  
<http://jp.fujitsu.com/fml/en/>

*For further information please contact:*

### North and South America

FUJITSU MICROELECTRONICS AMERICA, INC.  
1250 E. Arques Avenue, M/S 333  
Sunnyvale, CA 94085-5401, U.S.A.  
Tel: +1-408-737-5600 Fax: +1-408-737-5999  
<http://www.fma.fujitsu.com/>

### Asia Pacific

FUJITSU MICROELECTRONICS ASIA PTE. LTD.  
151 Lorong Chuan,  
#05-08 New Tech Park 556741 Singapore  
Tel : +65-6281-0770 Fax : +65-6281-0220  
<http://www.fmal.fujitsu.com/>

### Europe

FUJITSU MICROELECTRONICS EUROPE GmbH  
Pittlerstrasse 47, 63225 Langen, Germany  
Tel: +49-6103-690-0 Fax: +49-6103-690-122  
<http://emea.fujitsu.com/microelectronics/>

### FUJITSU MICROELECTRONICS SHANGHAI CO., LTD.

Rm. 3102, Bund Center, No.222 Yan An Road (E),  
Shanghai 200002, China  
Tel : +86-21-6146-3688 Fax : +86-21-6335-1605  
<http://cn.fujitsu.com/fmc/>

### Korea

FUJITSU MICROELECTRONICS KOREA LTD.  
206 Kosmo Tower Building, 1002 Daechi-Dong,  
Gangnam-Gu, Seoul 135-280, Republic of Korea  
Tel: +82-2-3484-7100 Fax: +82-2-3484-7111  
<http://kr.fujitsu.com/fmk/>

### FUJITSU MICROELECTRONICS PACIFIC ASIA LTD.

10/F., World Commerce Centre, 11 Canton Road,  
Tsimshatsui, Kowloon, Hong Kong  
Tel : +852-2377-0226 Fax : +852-2376-3269  
<http://cn.fujitsu.com/fmc/en/>

Specifications are subject to change without notice. For further information please contact each office.

### All Rights Reserved.

The contents of this document are subject to change without notice.

Customers are advised to consult with sales representatives before ordering.

The information, such as descriptions of function and application circuit examples, in this document are presented solely for the purpose of reference to show examples of operations and uses of FUJITSU MICROELECTRONICS device; FUJITSU MICROELECTRONICS does not warrant proper operation of the device with respect to use based on such information. When you develop equipment incorporating the device based on such information, you must assume any responsibility arising out of such use of the information.

FUJITSU MICROELECTRONICS assumes no liability for any damages whatsoever arising out of the use of the information.

Any information in this document, including descriptions of function and schematic diagrams, shall not be construed as license of the use or exercise of any intellectual property right, such as patent right or copyright, or any other right of FUJITSU MICROELECTRONICS or any third party or does FUJITSU MICROELECTRONICS warrant non-infringement of any third-party's intellectual property right or other right by using such information. FUJITSU MICROELECTRONICS assumes no liability for any infringement of the intellectual property rights or other rights of third parties which would result from the use of information contained herein.

The products described in this document are designed, developed and manufactured as contemplated for general use, including without limitation, ordinary industrial use, general office use, personal use, and household use, but are not designed, developed and manufactured as contemplated (1) for use accompanying fatal risks or dangers that, unless extremely high safety is secured, could have a serious effect to the public, and could lead directly to death, personal injury, severe physical damage or other loss (i.e., nuclear reaction control in nuclear facility, aircraft flight control, air traffic control, mass transport control, medical life support system, missile launch control in weapon system), or (2) for use requiring extremely high reliability (i.e., submersible repeater and artificial satellite).

Please note that FUJITSU MICROELECTRONICS will not be liable against you and/or any third party for any claims or damages arising in connection with above-mentioned uses of the products.

Any semiconductor devices have an inherent chance of failure. You must protect against injury, damage or loss from such failures by incorporating safety design measures into your facility and equipment such as redundancy, fire protection, and prevention of over-current levels and other abnormal operating conditions.

Exportation/release of any products described in this document may require necessary procedures in accordance with the regulations of the Foreign Exchange and Foreign Trade Control Law of Japan and/or US export control laws.

The company names and brand names herein are the trademarks or registered trademarks of their respective owners.

Edited: Sales Promotion Department